



DIVISION: 06 00 00—WOOD, PLASTICS AND COMPOSITES
Section: 06 17 53—Shop-Fabricated Wood Trusses

REPORT HOLDER:

BARRETTE STRUCTURAL DISTRIBUTION, INC.

EVALUATION SUBJECT:

OPEN JOIST 2000—ENGINEERED WOOD PRODUCT

ADDITIONAL LISTEE:

ALLEGHENY STRUCTURAL COMPONENTS

1.0 EVALUATION SCOPE

1.1 Compliance with the following codes:

- 2021, 2018, 2015, 2012 and 2009 *International Building Code*® (IBC)
- 2021, 2018, 2015, 2012 and 2009 *International Residential Code*® (IRC)
- 2013 *Abu Dhabi International Building Code* (ADIBC)[†]

[†]The ADIBC is based on the 2009 IBC. 2009 IBC code sections referenced in this report are the same sections in the ADIBC.

Property evaluated:

Structural

1.2 Evaluation to the following green code(s) and/or standards:

- 2019 California Green Building Standards Code (CALGreen), Title 24, Part 11
- 2015, 2012 and 2008 ICC 700 *National Green Building Standard*™ (ICC 700-2015, ICC 700-2012 and ICC 700-2008)

Attributes verified:

See Section 3.1.

2.0 USES

The Open Joist 2000 parallel chord trusses are used as structural repetitive members in roof or floor assemblies.

3.0 DESCRIPTION

3.1 General:

The Open Joist 2000 is a parallel chord truss, consisting of solid-sawn lumber top and bottom chords and diagonal and vertical web members. Chord members are

continuous and are fabricated with finger-joints located along the joist. The minimum distance between chord finger-joints is 24 inches (610 mm). Web members are continuous, with no finger-joints. Each end of the web member is finger-joined into the top and bottom chords and glued with a resorcinol adhesive. Chord and web dimensions and grade are dependent upon joist depth, span and design loads. Open Joist 2000 trusses are manufactured to depths of 9³/₈, 11⁷/₈, 13, 14 and 16 inches (238, 301, 330, 356 and 406 mm). See Figures 2 and 3 for configuration details.

Grade-stamped lumber used to fabricate the trusses is reinspected at the manufacturing plant prior to its use. The moisture content is verified and individual lumber pieces are machined to pattern and redried to a moisture content of less than 16 percent.

The attributes of the wood trusses have been verified as conforming to the provisions of (i) CALGreen Sections A4.404.3 for efficient framing techniques; (ii) ICC 700-2015 Section 608.1(b), 11.608.1(b) and 12.1.(A).606.1(b); ICC 700-2015 Section 608.1(b), 11.608.1(b) and 12.1.(A).606.1(b); ICC 700-2012 Section 608.1(2), 11.608.1(2) and 12(A).608.1 for resource-efficient materials; and (iii) ICC 700-2008 Section 607.1(2) for resource-efficient materials. Note that decisions on compliance for those areas rest with the user of this report. The user is advised of the project-specific provisions that may be contingent upon meeting specific conditions, and the verification of those conditions is outside the scope of this report. These codes or standards often provide supplemental information as guidance.

3.2 Materials:

3.2.1 Chord Members: Top and bottom chords are made of nominal 2-by-3 or 2-by-4, visually graded spruce-pine-fir (SPF), No. 2 or higher, or machine-stress-rated (MSR) SPF 2100f-1.8E or MSR SPF 2400f-2.0E.

3.2.2 Diagonal Web Members: Diagonal webs are made of nominally 2-by-2, 2-by-3 or 2-by-4 visually graded lumber in accordance with the approved quality control manual.

3.2.3 Vertical Web Members: Both ends of the truss are manufactured with solid vertical web members made of nominal 2-by-8 SPF, No. 2 or higher, or a laminated wood panel manufactured from SPF solid-sawn lumber meeting the requirements specified in the approved quality control manual for the fabrication of Open Joist 2000 trusses.

3.2.4 Adhesive: The adhesive used to fabricate the Open Joist 2000 trusses is two-component modified resorcinol

formaldehyde, complying with ANSI A190.1, CSA 0112.7-M, ASTM D2559, Section 5.4.3 of ASTM D5055-16 and requirements listed in the approved quality control manual.

4.0 DESIGN AND INSTALLATION

4.1 Design:

The Open Joist 2000 trusses must be designed to resist loading requirements as specified in the tables shown in this report. Details for rim joists, bridging and blocking at the joist ends, to prevent roll-over and to transfer lateral and vertical loads, must be provided in accordance with the design drawings and calculations submitted to the building official.

Tables 1, 2, 3, 4 and 5 of this report provide design live load tables for truss depths of $9\frac{3}{8}$, $11\frac{7}{8}$, 13, 14 and 16 inches (238, 301, 330, 356 and 406 mm), respectively. The tables are applicable only to uniformly loaded, simple-span joists, installed as repetitive members in floor or roof assemblies, where minimum $\frac{5}{8}$ -inch-thick (15.9 mm) sheathing is attached to the top flanges in accordance with the applicable code. The repetitive member factor, C_r , equals 1.0 when the Open Joist 2000 trusses are installed in accordance with this report.

4.2 Installation:

Open Joist 2000 trusses must be delivered to the jobsite with an assembly plan and a set of installation instructions published by the manufacturer.

Trusses must be installed in an assembly of repetitive trusses, spaced not more than 24 inches (610 mm), not less than three in number, and joined by minimum $\frac{5}{8}$ -inch-thick (15.9 mm) sheathing attached to the top flanges in accordance with the applicable code.

Required bearing length must be the longer of the bearing length calculated based on the bearing capacity of the supports, or 1.5 inches (38 mm). The ends of the joist member are permitted to be field-cut to the desired length to a maximum adjustment of $5\frac{1}{2}$ inches (140 mm) (see Figure 1, Detail B) at each end.

Maximum bearing permitted is such that the inside face of the bearing does not extend beyond 11 inches (279 mm) into the span from the end of an uncut joist (see Figure 1, Detail A), or beyond $5\frac{1}{2}$ inches (140 mm) into the span from the end of a joist that has its end cut to the maximum allowed (see Figure 1, Detail B).

Manufacturer's recommendations relating to rim joists, bridging, blocking, and other framing details, that are not within the scope of this report, must be verified by engineering analysis.

5.0 CONDITIONS OF USE

The Open Joist 2000 trusses described in this report comply with, or are suitable alternatives to what is specified in, those codes listed in Section 1.0 of this report, subject to the following conditions:

5.1 The trusses are installed in accordance with this report and the manufacturer's published installation instructions. The provisions of this report must govern should there be any conflict with the manufacturer's published installation instructions. Manufacturer's recommendations relating to rim joists, bridging or blocking that are not within the scope of this report must be verified by engineering analysis.

5.2 Design calculations, drawings, and details for specific applications, demonstrating compliance with this report, must be submitted to the code official. The calculations, drawings and details must be prepared by a registered design professional where required by the statutes of the jurisdiction in which the project is to be constructed. Design must be in accordance with Tables 1 through 5 of this report and the applicable code.

5.3 Damaged or defective joists must not be used.

5.4 Open Joist 2000 trusses must be used in covered, dry conditions. Dry conditions of use are those conditions of use represented by sawn lumber in which the moisture content is less than 19 percent.

5.5 Cutting or notching of any member of the joist is prohibited, except that up to $5\frac{1}{2}$ inches (140 mm) is permitted to be removed from each end of the joist (closed end).

5.6 Fire-retardant-treated or preservative-treated wood must not be used in the manufacture of these products.

5.7 Evaluation of the use of Open Joist 2000 trusses as a component of fire-resistance-rated roof or floor assemblies is outside the scope of this report.

5.8 Joists are produced by Open Joist 2000 Inc. or the additional listee specified in this report, under a quality control program with inspections by ICC-ES.

6.0 EVIDENCE SUBMITTED

Data in accordance with the ICC-ES Acceptance Criteria for Prefabricated Parallel Chord Wood Trusses (AC224), dated October 2018 (editorially revised January 2023).

7.0 IDENTIFICATION

7.1 The ICC-ES mark of conformity, electronic labeling, or the evaluation report number (ICC-ES ESR-1035) along with the name, registered trademark, or registered logo of the report holder or additional listee must be included in the product label.

7.2 In addition, the Open Joist 2000 must be identified with a stamp noting the plant location or identifier; the product name; and the production date.

7.3 The report holder's contact information is the following:

BARRETTE STRUCTURAL DISTRIBUTION, INC.
555 RANG SAINT-MALO
TROIS-RIVIERES, QUEBEC G8V 0A8
CANADA
(819) 374-6061
www.openjoist2000.com

7.4 The Additional Listee's contact information is the following:

ALLEGHENY STRUCTURAL COMPONENTS
3778 ONEIDA VALLEY ROAD
EMLENTON, PENNSYLVANIA 16373
(724) 867-1100
www.alleghenystructural.com

DETAIL A: MAXIMUM BEARING FOR UNCUT JOIST

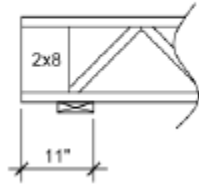

DETAIL B: MAXIMUM BEARING FOR CUT JOIST (MAXIMUM FIELD CUT PERMITTED)

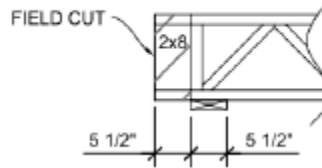

FIGURE 1—BEARING POSITION ALLOWED AND MAXIMUM FIELD CUT



TABLE 1 - ALLOWABLE LIVE LOAD (PSF) FOR OPEN JOIST 2000⁽¹⁾ (4)

TABLE 1a $\Delta L = L / 360$ $\Delta t = L / 240$ ⁽³⁾

JOIST DEPTH : 9 3/8"			DEAD LOAD = 15				DEAD LOAD = 20				DEAD LOAD = 25				DEAD LOAD = 30			
CHORDS		MANUF LENGTH	SPACING o.c.				SPACING o.c.				SPACING o.c.				SPACING o.c.			
SIZE	SPECIES / GRADE		12"	16"	19.2"	24"	12"	16"	19.2"	24"	12"	16"	19.2"	24"	12"	16"	19.2"	24"
3 x 2	SPF #2	10'-0"	209	153	125	97	204	148	120	92	199	143	115	87	194	138	110	82
3 x 2	SPF #2	11'-0"	183	134	109	84	178	129	104	79	173	124	99	74	168	119	94	69
3 x 2	SPF #2	12'-0"	147	110	92	73	147	110	90	68	147	107	85	63	146	102	80	58
3 x 2	SPF #2	13'-0"	115	86	72	58	115	86	72	58	115	86	72	55	115	86	70	50
3 x 2	SPF #2	14'-0"	94	71	59	47	94	71	59	47	94	71	59	45	94	71	58	40
3 x 2	SPF #2	15'-0"	77	58	48	38	77	58	48	38	77	58	48	37	77	58	48	32
3 x 2	SPF #2	16'-0"	64	48	40	32	64	48	40	32	64	48	40	31	64	48	40	26
4 x 2	SPF #2	17'-0"	70	53	44	35	70	53	44	35	70	53	44	31	70	53	40	26
4 x 2	SPF 2100F-1.8E	18'-0"	72	54	45	36	72	54	45	36	72	54	45	31	72	54	40	26
4 x 2	SPF 2100F-1.8E	19'-0"	61	46	38	30	61	46	38	30	61	46	37	25	61	44	32	20
4 x 2	SPF 2100F-1.8E	20'-0"	53	40	33	26	53	40	33	26	53	40	33	23	53	40	30	18

TABLE 1b $\Delta L = L / 480$ $\Delta t = L / 240$ ⁽³⁾

JOIST DEPTH : 9 3/8"			DEAD LOAD = 15				DEAD LOAD = 20				DEAD LOAD = 25				DEAD LOAD = 30			
CHORDS		MANUF LENGTH	SPACING o.c.				SPACING o.c.				SPACING o.c.				SPACING o.c.			
SIZE	SPECIES / GRADE		12"	16"	19.2"	24"	12"	16"	19.2"	24"	12"	16"	19.2"	24"	12"	16"	19.2"	24"
3 x 2	SPF #2	10'-0"	179	134	112	90	179	134	112	90	179	134	112	87	179	134	110	82
3 x 2	SPF #2	11'-0"	139	104	87	70	139	104	87	70	139	104	87	70	139	104	87	69
3 x 2	SPF #2	12'-0"	110	83	69	55	110	83	69	55	110	83	69	55	110	83	69	55
3 x 2	SPF #2	13'-0"	86	65	54	43	86	65	54	43	86	65	54	43	86	65	54	43
3 x 2	SPF #2	14'-0"	70	53	44	35	70	53	44	35	70	53	44	35	70	53	44	35
4 x 2	SPF #2	15'-0"	78	59	49	39	78	59	49	39	78	59	49	39	78	59	49	39
4 x 2	SPF #2	16'-0"	66	49	41	33	66	49	41	33	66	49	41	33	66	49	41	32
4 x 2	SPF 2100F-1.8E	17'-0"	66	49	41	33	66	49	41	33	66	49	41	33	66	49	41	30
4 x 2	SPF 2100F-1.8E	18'-0"	54	41	34	27	54	41	34	27	54	41	34	27	54	41	34	26
4 x 2	SPF 2100F-1.8E	19'-0"	46	35	29	23	46	35	29	23	46	35	29	23	46	35	29	20
4 x 2	SPF 2100F-1.8E	20'-0"	40	30	25	20	40	30	25	20	40	30	25	20	40	30	25	18

(1) Table is based on the assumption multiple joists (repetitive members) are installed in a floor or roof system with minimum 5/8-inch sheathing attached to the top flanges. No increase in allowable load for repetitive member use or duration of load allowed.

(2) Allowable load values in the table shall be reduced if repetitive member conditions are not met (20 percent for 3x2 and 13 percent for 4x2)

(3) Loads noted in the table are limited by live load deflection (ΔL) and total load deflection (Δt)

(4) "Manufactured length" refers to overall length which includes the possibility of a 5 1/2-inch bearing on both ends. To compute the allowable "clear span" subtract 11 inches from the tabulated manufactured length.

(5) SI conversions : 1 inch = 25.4 mm 1 foot = 304.8 mm 1 psf = 47.9 N / m²



TABLE 2 - ALLOWABLE LIVE LOAD (PSF) FOR OPEN JOIST 2000^{(1) (4)}

TABLE 2a $\Delta L = L / 360$ $\Delta t = L / 240$ ⁽³⁾

JOIST DEPTH : 11 7/8"			DEAD LOAD = 15				DEAD LOAD = 20				DEAD LOAD = 25				DEAD LOAD = 30			
CHORDS		MANUF LENGTH	SPACING o.c.				SPACING o.c.				SPACING o.c.				SPACING o.c.			
SIZE	SPECIES / GRADE		12"	16"	19.2"	24"	12"	16"	19.2"	24"	12"	16"	19.2"	24"	12"	16"	19.2"	24"
3 x 2	SPF #2	10'-0"	241	177	145	113	236	172	140	108	231	167	135	103	226	162	130	98
3 x 2	SPF #2	11'-0"	212	155	127	99	207	150	122	94	202	145	117	89	197	140	112	84
3 x 2	SPF #2	12'-0"	188	137	112	87	183	132	107	82	178	127	102	77	173	122	97	72
3 x 2	SPF #2	13'-0"	164	119	97	75	159	114	92	70	154	109	87	65	149	104	82	60
3 x 2	SPF #2	14'-0"	145	105	85	65	140	100	80	60	135	95	75	55	130	90	70	50
3 x 2	SPF #2	15'-0"	120	90	75	57	120	88	70	52	119	83	65	47	114	78	60	42
3 x 2	SPF #2	16'-0"	102	77	64	49	102	76	60	44	102	71	55	39	98	66	50	34
3 x 2	SPF #2	17'-0"	88	66	55	43	88	66	52	38	88	61	47	33	85	56	42	28
4 x 2	SPF #2	18'-0"	97	69	55	41	92	64	50	36	87	59	45	31	82	54	40	26
4 x 2	SPF #2	19'-0"	84	59	47	35	79	54	42	30	74	49	37	25	69	44	32	20
4 x 2	SPF 2100f-1.8E	20'-0"	93	70	58	43	93	68	53	38	92	63	48	33	87	58	43	28
4 x 2	SPF 2100f-1.8E	21'-0"	78	59	49	39	78	59	47	34	78	55	42	29	77	50	37	24
4 x 2	SPF 2100f-1.8E	22'-0"	67	50	42	34	67	50	42	30	67	49	37	25	67	44	32	20
4 x 2	SPF 2100f-1.8E	23'-0"	59	44	37	30	59	44	37	28	59	44	35	23	59	42	30	18

TABLE 2b $\Delta L = L / 480$ $\Delta t = L / 240$ ⁽³⁾

JOIST DEPTH : 11 7/8"			DEAD LOAD = 15				DEAD LOAD = 20				DEAD LOAD = 25				DEAD LOAD = 30			
CHORDS		MANUF LENGTH	SPACING o.c.				SPACING o.c.				SPACING o.c.				SPACING o.c.			
SIZE	SPECIES / GRADE		12"	16"	19.2"	24"	12"	16"	19.2"	24"	12"	16"	19.2"	24"	12"	16"	19.2"	24"
3 x 2	SPF #2	10'-0"	241	177	145	113	236	172	140	108	231	167	135	103	226	162	130	98
3 x 2	SPF #2	11'-0"	212	155	127	99	207	150	122	94	202	145	117	89	197	140	112	84
3 x 2	SPF #2	12'-0"	179	134	112	87	179	132	107	82	178	127	102	77	173	122	97	72
3 x 2	SPF #2	13'-0"	141	106	88	70	141	106	88	70	141	106	87	65	141	104	82	60
3 x 2	SPF #2	14'-0"	115	86	72	58	115	86	72	58	115	86	72	55	115	86	70	50
3 x 2	SPF #2	15'-0"	90	67	56	45	90	67	56	45	90	67	56	45	90	67	56	42
3 x 2	SPF #2	16'-0"	77	58	48	38	77	58	48	38	77	58	48	38	77	58	48	34
3 x 2	SPF #2	17'-0"	66	49	41	33	66	49	41	33	66	49	41	33	66	49	41	28
4 x 2	SPF #2	18'-0"	78	59	49	39	78	59	49	36	78	59	45	31	78	54	40	26
4 x 2	SPF #2	19'-0"	67	50	42	34	67	50	42	30	67	49	37	25	67	44	32	20
4 x 2	SPF 2100f-1.8E	20'-0"	70	53	44	35	70	53	44	35	70	53	44	33	70	53	43	28
4 x 2	SPF 2100f-1.8E	21'-0"	59	44	37	30	59	44	37	30	59	44	37	29	59	44	37	24
4 x 2	SPF 2100f-1.8E	22'-0"	51	38	32	26	51	38	32	26	51	38	32	25	51	38	32	20
4 x 2	SPF 2100f-1.8E	23'-0"	45	34	28	22	45	34	28	22	45	34	28	22	45	34	28	18

(1) Table is based on the assumption multiple joists (repetitive members) are installed in a floor or roof system with minimum 5/8-inch sheathing attached to the top flanges.

No increase in allowable load for repetitive member use or duration of load allowed.

(2) Allowable load values in the table shall be reduced if repetitive member conditions are not met (20 percent for 3x2 and 13 percent for 4x2)

(3) Loads noted in the table are limited by live load deflection (ΔL) and total load deflection (Δt)

(4) " Manufactured length " refers to overall length which includes the possibility of a 5 1/2-inch bearing on both ends. To compute the allowable "clear span" subtract 11 inches from the tabulated manufactured length.

(5) SI conversions : 1 inch = 25.4 mm 1 foot = 304.8 mm 1 psf = 47.9 N / m²



TABLE 3 - ALLOWABLE LIVE LOAD (PSF) FOR OPEN JOIST 2000^{(1) (4)}

TABLE 3a $\Delta L = L / 360$ $\Delta t = L / 240$ ⁽³⁾

JOIST DEPTH : 13"			DEAD LOAD = 15				DEAD LOAD = 20				DEAD LOAD = 25				DEAD LOAD = 30			
CHORDS		MANUF LENGTH	SPACING o.c.				SPACING o.c.				SPACING o.c.				SPACING o.c.			
SIZE	SPECIES / GRADE		12"	16"	19.2"	24"	12"	16"	19.2"	24"	12"	16"	19.2"	24"	12"	16"	19.2"	24"
3 x 2	SPF #2	10'-0"	273	201	165	129	268	196	160	124	263	191	155	119	258	186	150	114
3 x 2	SPF #2	11'-0"	241	177	145	113	236	172	140	108	231	167	135	103	226	162	130	98
3 x 2	SPF #2	12'-0"	212	155	127	99	207	150	122	94	202	145	117	89	197	140	112	84
3 x 2	SPF #2	13'-0"	188	137	112	87	183	132	107	82	178	127	102	77	173	122	97	72
3 x 2	SPF #2	14'-0"	169	123	100	77	164	118	95	72	159	113	90	67	154	108	85	62
3 x 2	SPF #2	15'-0"	150	109	88	67	146	104	83	62	140	99	78	57	135	94	73	52
3 x 2	SPF #2	16'-0"	128	93	75	57	124	88	70	52	119	83	65	47	114	78	60	42
3 x 2	SPF #2	17'-0"	106	79	65	49	106	76	60	44	103	71	55	39	98	66	50	34
3 x 2	SPF #2	18'-0"	91	68	57	43	91	66	52	38	90	61	47	33	85	56	42	28
4 x 2	SPF #2	19'-0"	102	73	58	43	97	68	53	38	92	63	48	33	87	58	43	28
4 x 2	SPF #2	20'-0"	91	64	51	38	86	59	46	33	81	54	41	28	76	49	36	23
4 x 2	SPF #2	21'-0"	80	59	47	35	79	54	42	30	74	49	37	25	69	44	32	20
4 x 2	SPF 2100f-1.8E	22'-0"	83	62	52	39	83	62	48	34	83	57	43	29	79	52	38	24
4 x 2	SPF 2100f-1.8E	23'-0"	74	55	46	36	74	55	44	31	74	52	39	26	72	47	34	21
4 x 2	SPF 2100f-1.8E	24'-0"	64	48	40	32	64	48	40	26	64	47	35	23	64	42	30	18
4 x 2	SPF 2100f-1.8E	25'-0"	58	43	36	29	58	43	36	26	58	43	32	21	58	38	27	16

TABLE 3b $\Delta L = L / 480$ $\Delta t = L / 240$ ⁽³⁾

JOIST DEPTH : 13"			DEAD LOAD = 15				DEAD LOAD = 20				DEAD LOAD = 25				DEAD LOAD = 30			
CHORDS		MANUF LENGTH	SPACING o.c.				SPACING o.c.				SPACING o.c.				SPACING o.c.			
SIZE	SPECIES / GRADE		12"	16"	19.2"	24"	12"	16"	19.2"	24"	12"	16"	19.2"	24"	12"	16"	19.2"	24"
3 x 2	SPF #2	10'-0"	273	201	165	129	268	196	160	124	263	191	155	119	258	186	150	114
3 x 2	SPF #2	11'-0"	241	177	145	113	236	172	140	108	231	167	135	103	226	162	130	98
3 x 2	SPF #2	12'-0"	212	155	127	99	207	150	122	94	202	145	117	89	197	140	112	84
3 x 2	SPF #2	13'-0"	171	128	107	86	171	128	107	82	171	127	102	77	171	122	97	72
3 x 2	SPF #2	14'-0"	142	107	89	71	142	107	89	71	142	107	89	67	142	107	85	62
3 x 2	SPF #2	15'-0"	114	85	71	57	114	85	71	57	114	85	71	57	114	85	71	52
3 x 2	SPF #2	16'-0"	96	72	60	48	96	72	60	48	96	72	60	47	96	72	60	42
3 x 2	SPF #2	17'-0"	80	60	50	40	80	60	50	40	80	60	50	39	80	60	50	34
3 x 2	SPF #2	18'-0"	69	52	43	34	69	52	43	34	69	52	43	33	69	52	42	28
4 x 2	SPF #2	19'-0"	80	60	50	40	80	60	50	38	80	60	48	33	80	58	43	28
4 x 2	SPF #2	20'-0"	69	52	43	34	69	52	43	33	69	52	41	28	69	49	36	23
4 x 2	SPF 2100f-1.8E	21'-0"	72	54	45	36	72	54	45	36	72	54	45	33	72	54	43	28
4 x 2	SPF 2100f-1.8E	22'-0"	64	48	40	32	64	48	40	32	64	48	40	29	64	48	38	24
4 x 2	SPF 2100f-1.8E	23'-0"	56	42	35	28	56	42	35	28	56	42	35	26	56	42	34	21
4 x 2	SPF 2100f-1.8E	24'-0"	48	36	30	24	48	36	30	24	48	36	30	23	48	36	30	18
4 x 2	SPF 2100f-1.8E	25'-0"	43	32	27	22	43	32	27	22	43	32	27	21	43	32	27	16

(1) Table is based on the assumption multiple joists (repetitive members) are installed in a floor or roof system with minimum 5/8-inch sheathing attached to the top flanges.

No increase in allowable load for repetitive member use or duration of load allowed.

(2) Allowable load values in the table shall be reduced if repetitive member conditions are not met (20 percent for 3x2 and 13 percent for 4x2)

(3) Loads noted in the table are limited by live load deflection (ΔL) and total load deflection (Δt)

(4) " Manufactured length " refers to overall length which includes the possibility of a 5 1/2-inch bearing on both ends. To compute the allowable "clear span" subtract 11 inches from the tabulated manufactured length.

(5) SI conversions : 1 inch = 25.4 mm 1 foot = 304.8 mm 1 psf = 47.9 N / m²



TABLE 4 - ALLOWABLE LIVE LOAD (PSF) FOR OPEN JOIST 2000 ^{(1) (4)}

TABLE 4a $\Delta L = L / 360$ $\Delta t = L / 240$ ⁽³⁾

JOIST DEPTH : 14"			DEAD LOAD = 15				DEAD LOAD = 20				DEAD LOAD = 25				DEAD LOAD = 30			
CHORDS		MANUF LENGTH	SPACING o.c.				SPACING o.c.				SPACING o.c.				SPACING o.c.			
SIZE	SPECIES / GRADE		12"	16"	19.2"	24"	12"	16"	19.2"	24"	12"	16"	19.2"	24"	12"	16"	19.2"	24"
3 x 2	SPF #2	10'-0"	273	201	165	129	268	196	160	124	263	191	155	119	258	186	150	114
3 x 2	SPF #2	11'-0"	241	177	145	113	236	172	140	108	231	167	135	103	226	162	130	98
3 x 2	SPF #2	12'-0"	212	155	127	99	207	150	122	94	202	145	117	89	197	140	112	84
3 x 2	SPF #2	13'-0"	188	137	112	87	183	132	107	82	178	127	102	77	173	122	97	72
3 x 2	SPF #2	14'-0"	169	123	100	77	164	118	95	72	159	113	90	67	154	108	85	62
3 x 2	SPF #2	15'-0"	150	109	88	67	145	104	83	62	140	99	78	57	135	94	73	52
3 x 2	SPF #2	16'-0"	128	93	75	57	124	88	70	52	119	83	65	47	114	78	60	42
3 x 2	SPF #2	17'-0"	106	79	65	49	106	76	60	44	103	71	55	39	98	66	50	34
3 x 2	SPF #2	18'-0"	91	68	57	43	91	66	52	38	90	61	47	33	85	56	42	28
4 x 2	SPF #2	19'-0"	102	73	58	43	97	68	53	38	92	63	48	33	87	58	43	28
4 x 2	SPF #2	20'-0"	91	64	51	38	86	59	46	33	81	54	41	28	76	49	36	23
4 x 2	SPF #2	21'-0"	80	59	47	35	79	54	42	30	74	49	37	25	69	44	32	20
4 x 2	SPF 2100f-1.8E	22'-0"	83	62	52	39	83	62	48	34	83	57	43	29	79	52	38	24
4 x 2	SPF 2100f-1.8E	23'-0"	74	55	46	36	74	55	44	31	74	52	39	26	72	47	34	21
4 x 2	SPF 2100f-1.8E	24'-0"	64	48	40	32	64	48	40	28	64	47	35	23	64	42	30	18
4 x 2	SPF 2100f-1.8E	25'-0"	58	43	36	29	58	43	36	26	58	43	32	21	58	38	27	16

TABLE 4b $\Delta L = L / 480$ $\Delta t = L / 240$ ⁽³⁾

JOIST DEPTH : 14"			DEAD LOAD = 15				DEAD LOAD = 20				DEAD LOAD = 25				DEAD LOAD = 30			
CHORDS		MANUF LENGTH	SPACING o.c.				SPACING o.c.				SPACING o.c.				SPACING o.c.			
SIZE	SPECIES / GRADE		12"	16"	19.2"	24"	12"	16"	19.2"	24"	12"	16"	19.2"	24"	12"	16"	19.2"	24"
3 x 2	SPF #2	10'-0"	273	201	165	129	268	196	160	124	263	191	155	119	258	186	150	114
3 x 2	SPF #2	11'-0"	241	177	145	113	236	172	140	108	231	167	135	103	226	162	130	98
3 x 2	SPF #2	12'-0"	212	155	127	99	207	150	122	94	202	145	117	89	197	140	112	84
3 x 2	SPF #2	13'-0"	171	128	107	86	171	128	107	82	171	127	102	77	171	122	97	72
3 x 2	SPF #2	14'-0"	142	107	89	71	142	107	89	71	142	107	89	67	142	107	85	62
3 x 2	SPF #2	15'-0"	114	85	71	57	114	85	71	57	114	85	71	57	114	85	71	52
3 x 2	SPF #2	16'-0"	96	72	60	48	96	72	60	48	96	72	60	47	96	72	60	42
3 x 2	SPF #2	17'-0"	80	60	50	40	80	60	50	40	80	60	50	39	80	60	50	34
3 x 2	SPF #2	18'-0"	69	52	43	34	69	52	43	34	69	52	43	33	69	52	42	28
4 x 2	SPF #2	19'-0"	80	60	50	40	80	60	50	38	80	60	48	33	80	58	43	28
4 x 2	SPF #2	20'-0"	69	52	43	34	69	52	43	33	69	52	41	28	69	49	36	23
4 x 2	SPF 2100f-1.8E	21'-0"	72	54	45	36	72	54	45	36	72	54	45	33	72	54	43	28
4 x 2	SPF 2100f-1.8E	22'-0"	64	48	40	32	64	48	40	32	64	48	40	29	64	48	38	24
4 x 2	SPF 2100f-1.8E	23'-0"	56	42	35	28	56	42	35	28	56	42	35	26	56	42	34	21
4 x 2	SPF 2100f-1.8E	24'-0"	48	36	30	24	48	36	30	24	48	36	30	23	48	36	30	18
4 x 2	SPF 2100f-1.8E	25'-0"	43	32	27	22	43	32	27	22	43	32	27	21	43	32	27	16

(1) Table is based on the assumption multiple joists (repetitive members) are installed in a floor or roof system with minimum 5/8-inch sheathing attached to the top flanges.

No increase in allowable load for repetitive member use or duration of load allowed.

(2) Allowable load values in the table shall be reduced if repetitive member conditions are not met (20 percent for 3x2 and 13 percent for 4x2)

(3) Loads noted in the table are limited by live load deflection (ΔL) and total load deflection (Δt)

(4) " Manufactured length " refers to overall length which includes the possibility of a 5 1/2-inch bearing on both ends. To compute the allowable "clear span" subtract 11 inches from the tabulated manufactured length.

(5) SI conversions : 1 inch = 25.4 mm 1 foot = 304.8 mm 1 psf = 47.9 N / m²



TABLE 5 - ALLOWABLE LIVE LOAD (PSF) FOR OPEN JOIST 2000⁽¹⁾⁽⁴⁾

TABLE 5a $\Delta L = L / 360$ $\Delta t = L / 240$ ⁽³⁾

JOIST DEPTH : 16"			DEAD LOAD = 15				DEAD LOAD = 20				DEAD LOAD = 25				DEAD LOAD = 30			
SIZE	CHORDS		SPACING o.c.				SPACING o.c.				SPACING o.c.				SPACING o.c.			
	SPECIES / GRADE	MANUF LENGTH	12"	16"	19.2"	24"	12"	16"	19.2"	24"	12"	16"	19.2"	24"	12"	16"	19.2"	24"
3 x 2	SPF #2	10'-0"	281	207	170	133	276	202	165	128	271	197	160	123	266	192	155	118
3 x 2	SPF #2	11'-0"	241	177	145	113	236	172	140	108	231	167	135	103	226	162	130	98
3 x 2	SPF #2	12'-0"	212	155	127	99	207	150	122	94	202	145	117	89	197	140	112	84
3 x 2	SPF #2	13'-0"	188	137	112	87	183	132	107	82	178	127	102	77	173	122	97	72
3 x 2	SPF #2	14'-0"	169	123	100	77	164	118	95	72	159	113	90	67	154	108	85	62
3 x 2	SPF #2	15'-0"	153	111	90	69	148	106	85	64	143	101	80	59	138	96	75	54
3 x 2	SPF #2	16'-0"	145	105	85	65	140	100	80	60	135	95	75	55	130	90	70	50
3 x 2	SPF #2	17'-0"	142	103	83	63	137	98	78	58	132	93	73	53	127	88	68	48
4 x 2	SPF #2	18'-0"	169	123	100	77	164	118	95	72	159	113	90	67	154	108	85	62
4 x 2	SPF #2	19'-0"	161	117	95	73	156	112	90	68	151	107	85	63	146	102	80	58
4 x 2	SPF #2	20'-0"	154	112	91	70	149	107	86	65	144	102	81	60	139	97	76	55
4 x 2	SPF #2	21'-0"	148	107	87	67	143	102	82	62	138	97	77	57	133	92	72	52
4 x 2	SPF #2	22'-0"	137	99	80	61	132	94	75	56	127	89	70	51	122	84	65	46
4 x 2	SPF 2100F-1.8E	23'-0"	127	91	74	56	122	86	69	51	117	81	64	46	112	76	59	41
4 x 2	SPF 2100F-1.8E	24'-0"	104	78	65	52	102	76	64	47	94	70	59	42	86	64	54	37
4 x 2	SPF 2100F-1.8E	25'-0"	96	72	60	47	92	69	58	42	84	63	53	37	76	57	48	32
4 x 2	SPF 2100F-1.8E	26'-0"	83	62	52	42	81	61	51	37	73	55	46	32	65	49	41	27
4 x 2	SPF 2400F-2.0E	27'-0"	83	62	52	40	81	61	49	35	73	55	44	30	65	49	39	25
4 x 2	SPF 2400F-2.0E	28'-0"	75	56	47	36	73	55	44	31	65	49	39	26	60	45	34	21
4 x 2	SPF 2400F-2.0E	29'-0"	64	48	40	32	64	48	39	27	64	46	34	22	56	41	29	17
4 x 2	SPF 2400F-2.0E	30'-0"	56	42	35	28	56	42	35	24	56	41	30	19	48	36	25	14

TABLE 5b $\Delta L = L / 480$ $\Delta t = L / 240$ ⁽³⁾

JOIST DEPTH : 16"			DEAD LOAD = 15				DEAD LOAD = 20				DEAD LOAD = 25				DEAD LOAD = 30			
SIZE	CHORDS		SPACING o.c.				SPACING o.c.				SPACING o.c.				SPACING o.c.			
	SPECIES / GRADE	MANUF LENGTH	12"	16"	19.2"	24"	12"	16"	19.2"	24"	12"	16"	19.2"	24"	12"	16"	19.2"	24"
3 x 2	SPF #2	10'-0"	281	207	170	133	276	202	165	128	271	197	160	123	266	192	155	118
3 x 2	SPF #2	11'-0"	241	177	145	113	236	172	140	108	231	167	135	103	226	162	130	98
3 x 2	SPF #2	12'-0"	212	155	127	99	207	150	122	94	202	145	117	89	197	140	112	84
3 x 2	SPF #2	13'-0"	188	137	112	87	183	132	107	82	178	127	102	77	173	122	97	72
3 x 2	SPF #2	14'-0"	169	123	100	77	164	118	95	72	159	113	90	67	154	108	85	62
3 x 2	SPF #2	15'-0"	153	111	90	69	148	106	85	64	143	101	80	59	138	96	75	54
3 x 2	SPF #2	16'-0"	145	105	85	65	140	100	80	60	135	95	75	55	130	90	70	50
3 x 2	SPF #2	17'-0"	142	103	83	63	137	98	78	58	132	93	73	53	127	88	68	48
4 x 2	SPF #2	18'-0"	169	123	100	77	164	118	95	72	159	113	90	67	154	108	85	62
4 x 2	SPF #2	19'-0"	144	108	90	73	144	108	90	68	139	103	85	63	134	98	80	58
4 x 2	SPF #2	20'-0"	128	96	80	64	128	96	80	64	128	96	80	60	123	91	75	55
4 x 2	SPF #2	21'-0"	112	84	70	56	112	84	70	56	112	84	70	56	112	84	70	52
4 x 2	SPF #2	22'-0"	88	66	55	44	88	66	55	44	88	66	55	44	88	66	55	44
4 x 2	SPF 2100F-1.8E	23'-0"	80	60	50	40	80	60	50	40	80	60	50	40	80	60	50	40
4 x 2	SPF 2100F-1.8E	24'-0"	75	56	47	38	75	56	47	38	75	56	47	38	75	56	47	37
4 x 2	SPF 2100F-1.8E	25'-0"	70	52	44	35	70	52	44	35	70	52	44	35	70	52	44	32
4 x 2	SPF 2100F-1.8E	26'-0"	64	48	40	32	64	48	40	32	64	48	40	32	64	48	40	27
4 x 2	SPF 2400F-2.0E	27'-0"	60	45	38	30	60	45	38	30	60	45	38	30	60	45	38	25
4 x 2	SPF 2400F-2.0E	28'-0"	54	40	34	27	54	40	34	27	54	40	34	26	54	40	34	21
4 x 2	SPF 2400F-2.0E	29'-0"	48	36	30	24	48	36	30	24	48	36	30	22	48	36	29	17
4 x 2	SPF 2400F-2.0E	30'-0"	41	31	26	21	41	31	26	21	41	31	26	19	41	31	25	14

(1) Table is based on the assumption multiple joists (repetitive members) are installed in a floor or roof system with minimum 5/8-inch sheathing attached to the top flanges.

No increase in allowable load for repetitive member use or duration of load allowed.

(2) Allowable load values in the table must be reduced if repetitive member conditions are not met (20 percent for 3x2 and 13 percent for 4x2)

(3) Loads noted in the table are limited by live load deflection (ΔL) and total load deflection (Δt)

(4) " Manufactured length " refers to overall length which includes the possibility of a 5 1/2-inch bearing on both ends. To compute the allowable " clear span " subtract 11 inches from the tabulated manufactured length.

(5) SI conversions : 1 inch = 25,4 mm 1 foot = 304,8 mm 1 psf = 47,9 N / m²

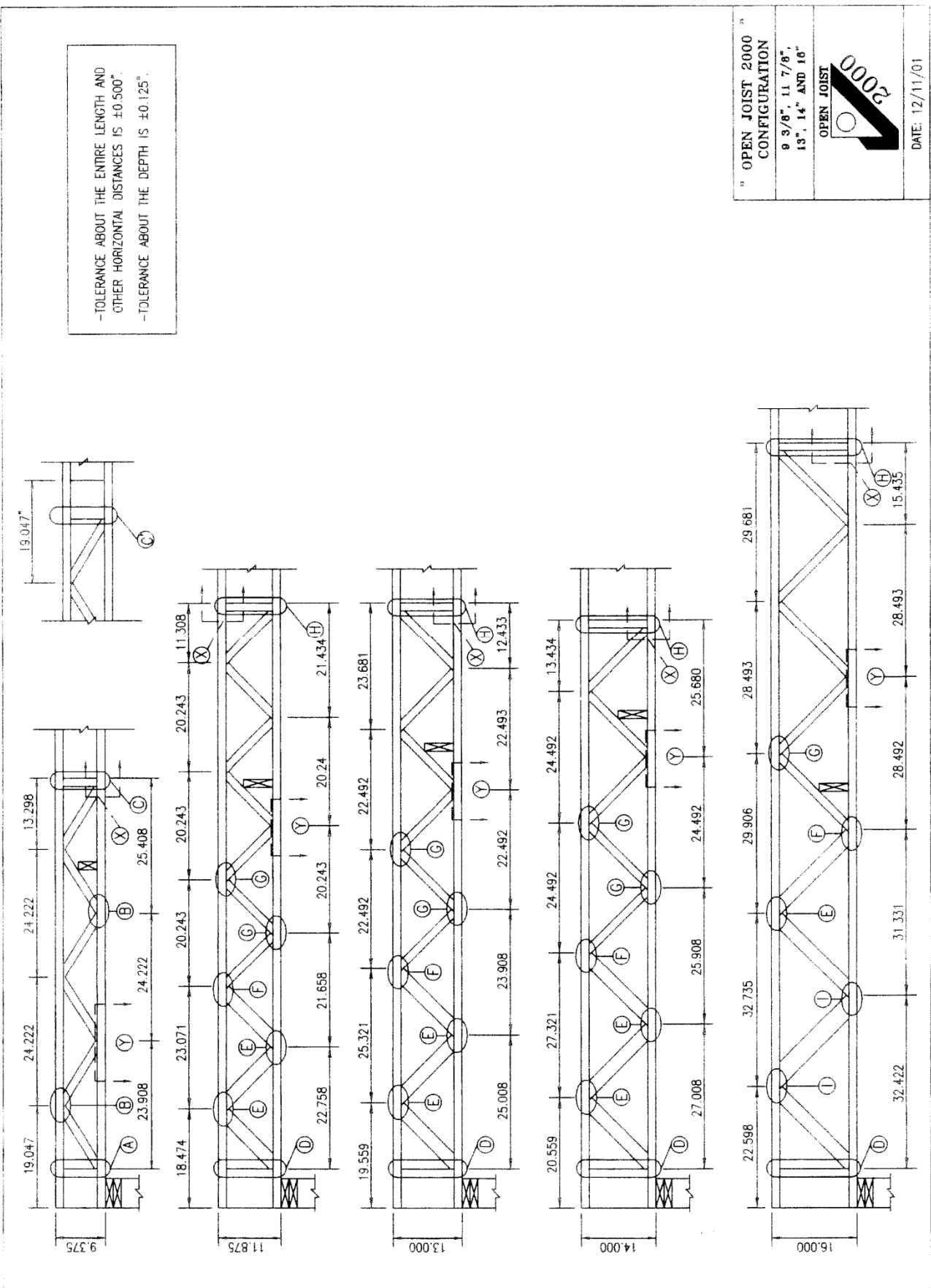

FIGURE 2—TYPICAL TRUSSES

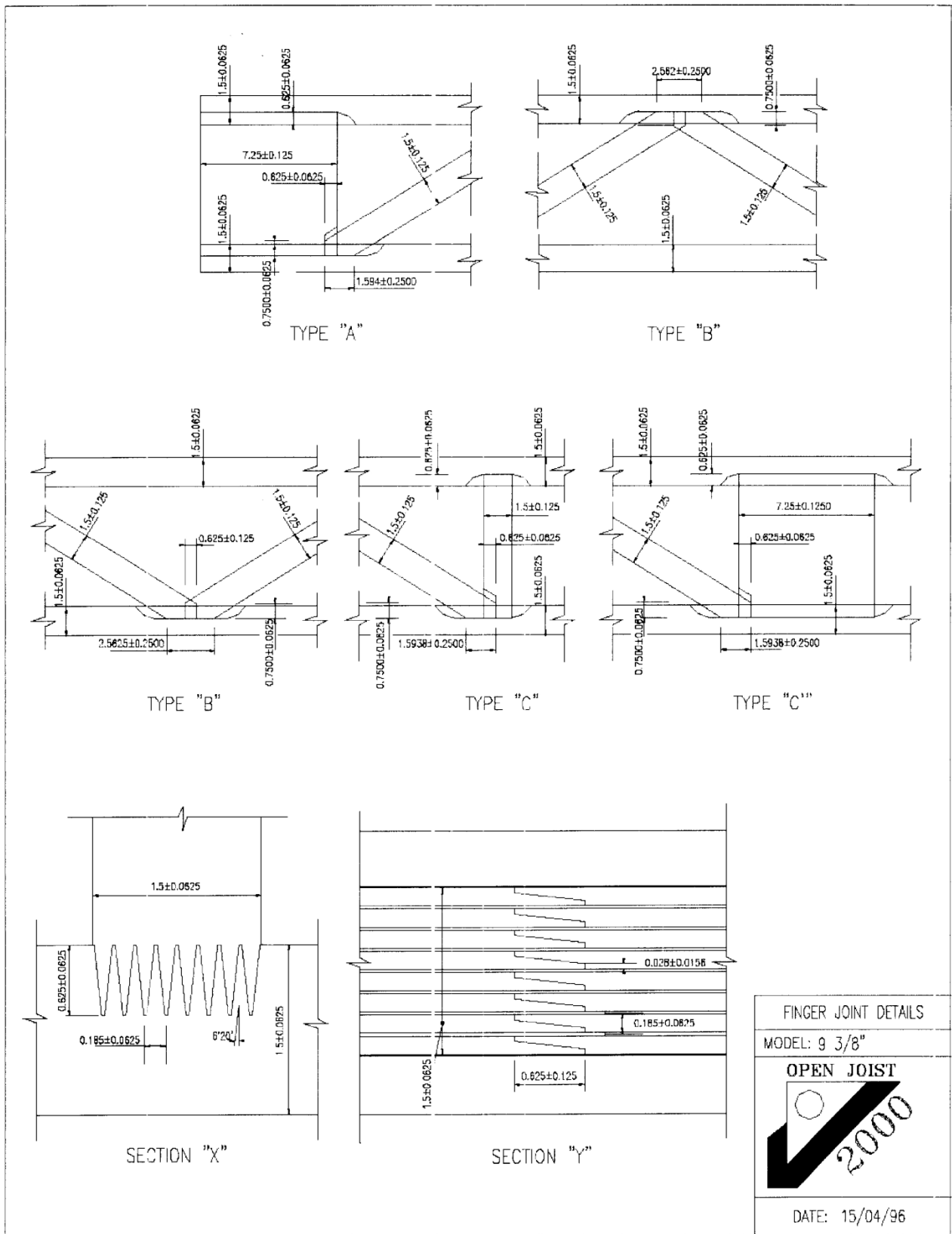

FIGURE 3—TYPICAL TRUSS DETAILS

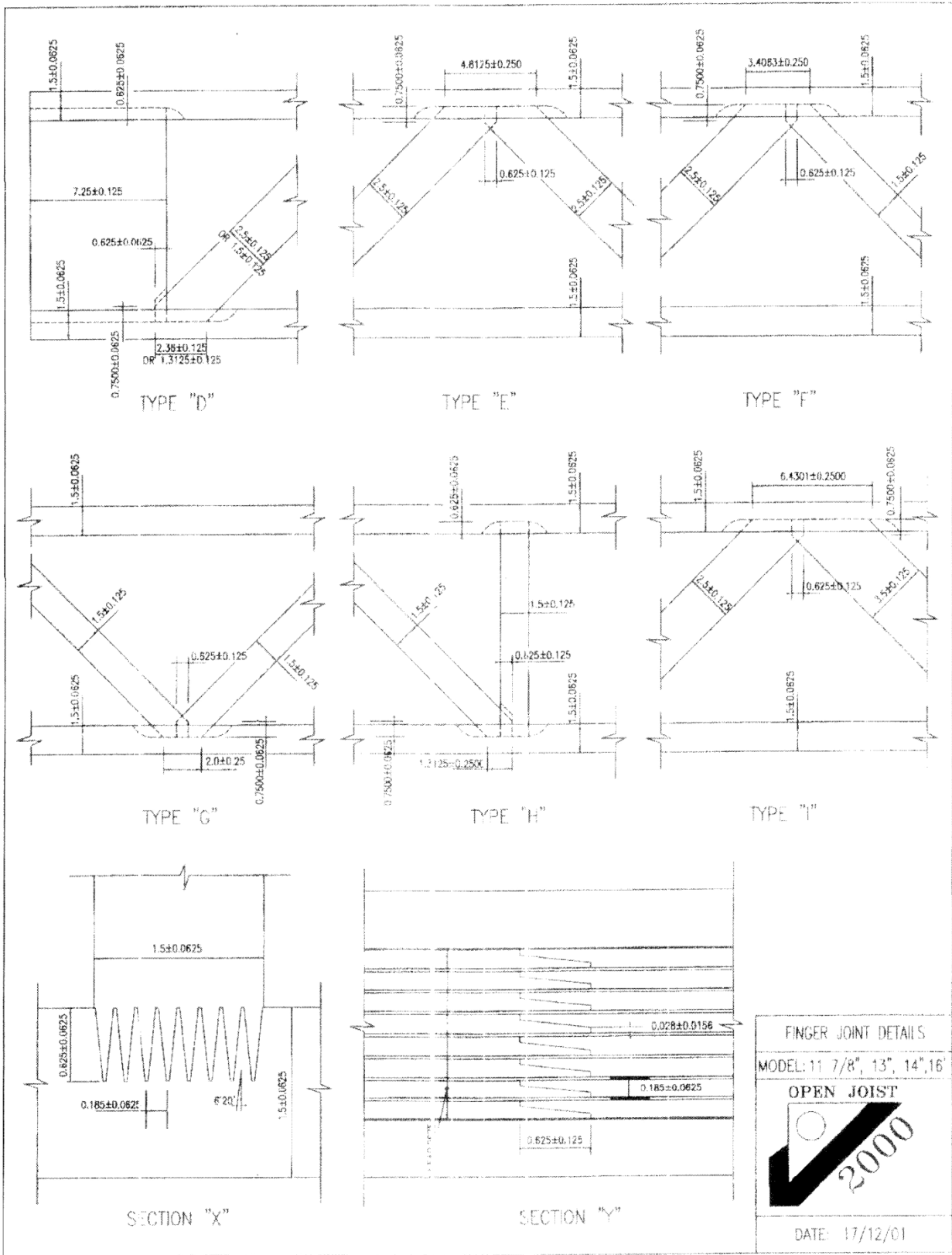

FIGURE 3—TYPICAL TRUSS DETAILS (Continued)