

2023 TREX SIGNATURE<sup>®</sup>  
DECKING INSTALLATION GUIDE



*Signature*<sup>®</sup>

TREX

## SAFETY

When working on any construction project, you should wear protective clothing and safety equipment. Wear safety glasses, gloves, a dust mask and long sleeves, particularly when cutting in confined spaces.

Trex decking and railing are heavier and more flexible than wood. **DO NOT** try to lift the same quantity of Trex boards as you would traditional lumber. Go to [www.trex.com](http://www.trex.com) for Safety Data Sheets (SDS).

## TOOLS

### SAWS

**Miter Saw:**  
When using a miter saw we recommend using the Trex Blade™ or a carbide-tipped blade with 60 teeth or more. The Trex Blade comes in three different sizes and is ideal for cutting all Trex decking and railing products.

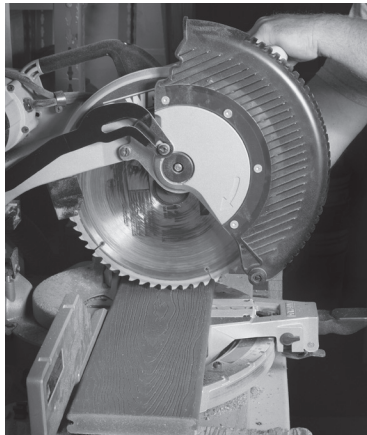

**Jigsaw:**  
For detailed and/or small cuts (i.e., cutting deck board to fit around a post), a jigsaw with a carbide-tipped blade can be used.



### DRILLS

Install Trex recommended fasteners with standard power drills, impact drivers (use care if using impact drivers).



\*Trex® Blade™ is manufactured and sold by Freud Tools, Inc. under a Trademark License Agreement with Trex Company, Inc.

### SPECIFIC DECK BOARD ATTACHMENT TOOLS

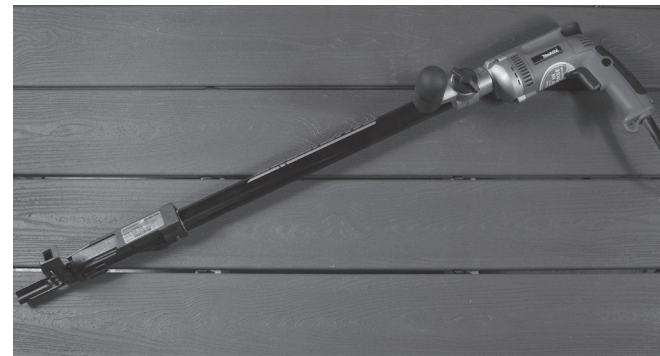

**Screw Guns:**  
Some Trex recommended deck fasteners are compatible with screw guns. Refer to the recommended fasteners page for more information.

**TigerClaw® Pneumatic Gun:**  
If choosing the TigerClaw TC-G Hidden Fasteners, the TigerClaw pneumatic gun is a terrific option that allows for quicker install time.



**Trex Router Bit:**  
Trex decking routs to give extremely crisp edges when using the Trex Router Bit with standard router, and can be used with all Trex Hideaway Hidden Fasteners.

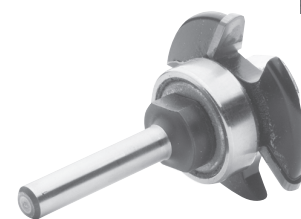
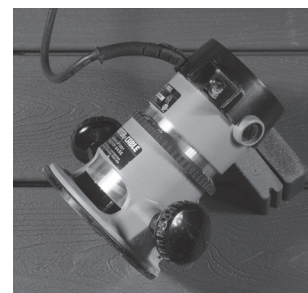

\*Tiger Claw® is a registered trademark of Tiger Claw, Inc.

## SIGNATURE® DECKING CARE AND CLEANING GUIDE

All exterior building materials require cleaning. Generally, soap and water is all that is required to clean Signature decking products. For additional information, see below.

PROBLEM	SOLUTION
Dirt and Debris	The affected area should be sprayed off with a hose to remove surface debris. Use warm soapy water and a soft bristle brush to remove dirt and debris from the embossing pattern.
Using a Pressure Washer (General Cleaning Issues)	A pressure washer with no greater than 3100 psi** that has a fan attachment/adjustment and soap dispenser may be used to remove dirt or mud. Spray deck with soap, then follow by gently scrubbing each deck board with a soft bristle brush. Spray/rinse each individual deck board using a fan tip no closer than 8-in (203 mm) from the decking surface. <b>RINSE THOROUGHLY.</b> If dirty water from cleaning is left to dry, a film will remain on the decking surface.
Issues with Concrete, Cement, Mortar, or Stucco Dust	When working with cement, concrete, mortar, or stucco, protect the decking as much as possible in order to not get dust particles on the decking surface. These particles, once they get hot or wet, can cause a reaction on the decking surface and are very difficult to remove. If particles get on the decking surface, Trex recommends using Sakrete™ Concrete Dissolver ( <a href="http://www.sakrete.com/products/concrete-dissolver">www.sakrete.com/products/concrete-dissolver</a> ). <b>BE SURE TO FOLLOW MANUFACTURER'S INSTRUCTIONS.</b>
Hard Water Staining	Hard water is water with high amounts of mineral deposits like lime, silica and calcium. When the water dries, deposits are left behind, leaving unsightly spots on surfaces. This is not a defect of Trex products but an issue with the water itself. Generally, these deposits can be cleaned with white vinegar on decking surfaces. Rinsing is required, so care should be taken to not use hard water for this purpose. If hard water must be used, dry with a cloth or use a blower to dry surfaces. In some cases a deck brightener product may also be used to help clean hard water stains.
Chalk Lines	Most colored chinks are permanent and may discolor the surface. Use only Irwin Strait-Line® Dust-Off Marking Chalk (purple), available at <a href="http://www.irwin.com">www.irwin.com</a> .
Tannins Due to Debris	Remove all debris from the deck using a hose or broom. Once the deck surface is dry, apply a deck "brightener" to the deck as directed by the manufacturer. Deck Brighteners contain oxalic acid, which will also remove tannins.
Ice and Snow	A plastic shovel may be used to remove snow from the deck. Use calcium chloride or rock salt to melt the snow and ice from the deck surface.
Oil, Grease, and Food	All food spills should be removed as soon as possible. The surface must be cleaned within seven days to maintain the stain warranty. To remove, spray off with a hose and use warm, soapy water and a soft bristle brush to remove spills from the embossing pattern.
Mold and Mildew	If debris such as pollen and dirt is allowed to remain on the deck surface, mold can feed on the biofilm. Using a hose and warm, soapy water with a soft bristle brush is recommended to remove the food source and mold.



# SIGNATURE® DECKING CARE AND CLEANING GUIDE

PROBLEM	SOLUTION
Trex and Static Electricity	<p>While this is not common, static electricity can occur on walking surfaces in dry climates or in areas where dry winds and dust-borne particles lay on the decking surfaces. Static electricity can build up on occupants walking across any composite decking surface, including Trex, then produce a small static shock if they touch a grounded metal surface such as railing, door, etc.</p> <p>This condition can be decreased greatly with the use of a product call ACL Staticide®. Two products tested were General Purpose Staticide® and Heavy Duty Staticide®. Both are effective in greatly reducing static electricity on Trex decking surfaces. Apply full strength, using a mop on a dry decking surface, and allow to dry; no rinsing or diluting needed. Products are non-toxic, non-flammable, non-staining (will not change the color of decking surface), completely biodegradable, and safe to use. Product is water-based and may require a second application after rain or other weather conditions. Over a period of time, the effect of static will dissipate naturally on the decking surface.</p> <p>See link for more information on product: <a href="https://www.aclstaticide.com/categories/anti-static-coatings">https://www.aclstaticide.com/categories/anti-static-coatings</a></p>
Rubber Mats	Use caution when using rubber-backed mats i.e., welcome mats, etc. as these may contain substances that can sometimes discolor or lighten the decking surface.
Job Site Storage	Store decking on a flat level surface and ALWAYS use proper supports (dunnage). <b>DO NOT</b> store directly on the ground. When stacking decking bundles, supports (dunnage) should start approximately 8-in (203 mm) from each end and be spaced approximately 2-ft (0.61m) on center. In addition, supports (dunnage) should line up vertically/perpendicular to the decking product. Adjust support blocks (dunnage) accordingly if bundles are loose. For all other decking products maximum stack height is 14 bundles ( <b>IMPORTANT TO NOTE THAT PROPER DUNNAGE SPACING MUST BE IN PLACE FOR THESE HEIGHTS</b> ). When stacking multiple bundles, ensure that dunnage lines up vertically down through each stack. ALWAYS cover decking products on site until ready to be installed.

Strait-Line® is a registered trademark of Irwin Industrial Tool Company.

Sakrete™ is a trademark of Oldcastle APG, a CRH Company.

\*Use of products containing bleach or acid can lighten the surface of Trex. Use in an inconspicuous area to determine whether you like the effect. Neither product will affect the structural integrity of Trex.

\*\*Use of a pressure washer greater than 3100 psi could damage the boards and void the warranty.

## PLANNING AHEAD

### TREX DECKING:

- » When installing ANY Trex decking product, it is a good idea to mix and match all of the boards on the job site prior to installation to ensure an appealing mix of light and dark tones.
- » For added protection to wood framing, use Trex® Protect® Joist and Beam Tape on the top of joists, rim joists, and ledger boards to help prevent rot and wood decay. Refer to [trexprotect.com](http://trexprotect.com) for more details.

### TREX DECKING TEMPERATURE:

Like many other outdoor surfaces, such as concrete, asphalt, beach sand, wood decking, other brands of composite decking, etc., Trex decking can get hot due to weather and sun exposure. On such days, care needs to be taken to make sure skin does not have extended contact with the surface of the deck, especially with young children and those with special needs. Please note also that the darker the color, the hotter the deck will feel. For hotter climates, consumers should consider choosing a lighter color.

### TREX PRODUCTS NEAR LOW-E WINDOW:

Low-E glass reflects more sunlight. It has been observed that the extra reflectivity, combined with any concavity in the glass, can act like a concave mirror. This mirror effect concentrates sunlight onto outdoor objects, including that of decking and railing. This can result in an extreme amount of heat concentrated on areas of the decking surface. This can sometimes char the decking surface or cause the decking to slightly bow.

### TREX® OUTDOOR LIGHTING™:

- » Plan locations of lights, power supply, timer, and dimmer. These should be accessible for service if necessary.
- » Install wiring before decking and railing have been installed.
- » **DO NOT** run wires between joists and deck boards.

Refer to [www.trex.com](http://www.trex.com) to view detailed Trex lighting instructions.

### TREX® RAINESCAPE® DECK DRAINAGE SYSTEM:

- » Plan ahead for deck layout to allow for proper placement of Trex RainEscape within the joist system.
- » Make sure joists are straight and square.

See [www.trex.com](http://www.trex.com) for more information on Trex RainEscape recommendations and installation. Trex RainEscape is manufactured and distributed by IBP, LLC, under a trademark license with Trex Company, Inc.

### INSTALLING HOT TUBS, PLANTERS, AND SEATING:

- » Plan ahead proper joist spanning if required (this is especially important if installing a hot tub).
- » Refer to page 12 for Trex Decking Span Chart for specific loads.

Call 1-800-BUY-TREX for detailed questions.

### INSTALLING FIREPLACES AND/OR FIRE PITS WITH TREX DECKING:

- » Determine if fire will be gas or wood burning. (Note: Most fire pits shown in Trex images are gas burning.)
- » For gas, the fire pit is installed by cutting around the Trex decking. **It is not to be installed on top of Trex decking.** A fire-resistant material is installed under the fire pit and a protective wall made from stone or other fire-resistant material is installed to hold fire pit in place and also protect the decking from heat.
- » For wood, fire pits are not recommended on top of Trex decking unless using a product called DeckProtect®. Wood-burning fire pits can damage the decking due to extreme heat from the bottom of the fire pit and/or burning embers shooting onto the decking. DeckProtect® was tested on all Trex decking and there were no issues with burning of the decking surface when placed directly under a standard size portable fire pit along with the accompanying rack (Note: Rack is not available for all sizes, so check with manufacturer first for verification). Trex does recommend that the DeckProtect® padding/rack be moved from time to time for general cleaning underneath. It should be noted that even when using DeckProtect®, burning embers could shoot beyond the protective mat and burn the deck.

For more information about this product, please visit their website at [www.deckprotect.net](http://www.deckprotect.net) or call 1-800-BUY-TREX. DeckProtect® is a registered trademark of Infinite Heat Solutions.

**NOTE:** You can always reference the Design Tools Section on [www.trex.com](http://www.trex.com) for additional planning ahead aids.

# TREX SIGNATURE® DECKING

## 1" SQUARE-EDGE BOARD





ITEM	DESCRIPTION	ACTUAL DIMENSIONS
WY010620NS01	1 x 6 x 20' Signature Square Board WY	.94 in x 5.5 in x 20 ft (24 mm x 140 mm x 609 cm)
OC010620NS01	1 x 6 x 20' Signature Square Board OC	.94 in x 5.5 in x 20 ft (24 mm x 140 mm x 609 cm)

## 1" GROOVED-EDGE BOARD

ITEM	DESCRIPTION	ACTUAL DIMENSIONS
WY010620NG01	1 x 6 x 20' Signature Square Board WY	.94 in x 5.5 in x 20 ft (24 mm x 140 mm x 609 cm)
OC010620NG01	1 x 6 x 20' Signature Square Board OC	.94 in x 5.5 in x 20 ft (24 mm x 140 mm x 609 cm)
WY010616NG01	1 x 6 x 16' Signature Grooved Board WY	.94 in x 5.5 in x 16 ft (24 mm x 140 mm x 487 cm)
OC010616NG01	1 x 6 x 16' Signature Grooved Board OC	.94 in x 5.5 in x 16 ft (24 mm x 140 mm x 487 cm)
WY010612NG01	1 x 6 x 12' Signature Grooved Board WY	.94 in x 5.5 in x 12 ft (24 mm x 140 mm x 365 cm)
OC010612NG01	1 x 6 x 12' Signature Grooved Board OC	.94 in x 5.5 in x 12 ft (24 mm x 140 mm x 365 cm)

XX = COLOR PREFIX WY Whidbey OC Ocracoke

To learn more about installation requirements and accessories, download our Installation Guide at [trex.com/literature](http://trex.com/literature)

TREX HIDEAWAY® HIDDEN FASTENING SYSTEM	DESCRIPTION	ITEM NUMBER
Universal Fastener (glass-filled nylon) 	50 sq. ft (4.6 sq. m) box 500 sq. ft (46.5 sq. m) bucket	UNIVCONCLIP DA00002
Universal Starter Clip 	400 sq. ft (37 sq. m) bag	UNIVSTARTCLIP
Router Bit 	Router Bit	ROUTBIT
Universal Fastener Installation Tool 	Universal Fastener Installation Tool	ONESTEPTL

# SIGNATURE® DECKING RECOMMENDED FASTENERS

SIGNATURE DECKING — HIDDEN FASTENERS
Trex Hideaway® Universal Hidden Fastener
TigerClaw® TC-G Hidden Fastener
Cortex® Concealed Fasteners
SIGNATURE WHIDBEY DECKING — BEST COLOR-MATCHED COMPOSITE SCREWS
FastenMaster® TrapEase 3 - Ultimate Composite Deck Screw – Island Mist
Starborn® Cap-Tor® xd - Epoxy Coated – Grey #37 (available collated for Muro CH7390 Driver) (2" are approved for sleeper & roof top applications only)
SIGNATURE OCRACOCKE DECKING — BEST COLOR-MATCHED COMPOSITE SCREWS
FastenMaster® TrapEase 3 - Ultimate Composite Deck Screw – Havana Gold
Screw Products C-Deck Exterior Star Drive Composite Deck Screw – Mountain Cedar
DECKING — COMPOSITE SCREWS (approved but non-color matching)
Simpson Strong Tie Deck Drive™ DCU Composite Screw – Coated Carbon Steel or Stainless (Collated & Handdrive)
Starborn® Cap-Tor® xd Stainless (collated and hand-drive available) (2" are approved for sleeper & roof top applications only)

## IMPORTANT ADDITIONAL INFORMATION:

- Trex requires the use of two screws per joist.
- All recommended screws are designed to be installed flush with decking surface. DO NOT countersink screws.
- Use recommended stainless steel screws in any areas near bodies of saltwater.
- All decking products are approved for use with Trex Hideaway Hidden Fasteners; thus all decking products can be routed according to our instructions.
- Simpson Strong-Tie Deck Drive DCU Composite Screw in collated versions works with Quik Drive gun.
- FastenMaster TrapEase 3 screws are not for use with sleeper systems. Refer to FastenMaster® literature for more information.

If any condition occurs which is attributable to the use of non-recommended fasteners, such condition shall not be covered under the Trex Limited Warranty.

*FastenMaster® TrapEase® and Cortex® are registered trademarks of OMG, Inc.*

*Quik Drive® is a registered trademark and Composi-Lok™ is a trademark of Simpson Strong-Tie Company, Inc.*

*DeckFast® Cap-Tor® xd and HeadCote® Cap-Tor® xd are registered trademarks of Starborn Industries Inc.*

*C-Deck Exterior Star Deck Composite Deck Screw is a product of Screw Products Inc.*



# TREX® FASCIA INSTALLATION RECOMMENDATIONS

## GENERAL NOTES:

- » Trex Fascia utilized around the perimeter of a deck must be gapped with the same requirements as Trex decking to allow for expansion/contraction of the fascia.
- » When using full size 1 x 12 fascia on 2 x 8 or larger rim joist 3 screws are required. Top screw should be placed 1" from the top of the rim joist, the second screw in the center of the rim joist, and the third screw 1" from the bottom of the rim joist.

## WHEN USING APPROVED FASCIA FASTENERS:

- » Approved fascia fasteners can only be used with 1 x 8 or 1 x 12 fascia product and cannot be used with decking products that are being used as fascia trim or stair risers.

### Method 1: Fascia Under Decking

(Note: reflects 2x8 fascia installation & square-edge decking)

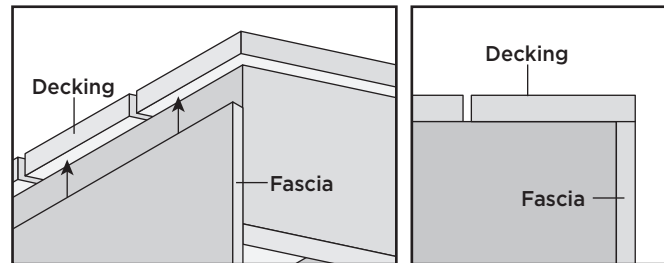

Install fascia UNDER decking edges/ends. This will optimize the aesthetics of the installation.

### Method 2: Fascia Beside Decking

(Note: spacers below reflect 2x8 fascia installation)

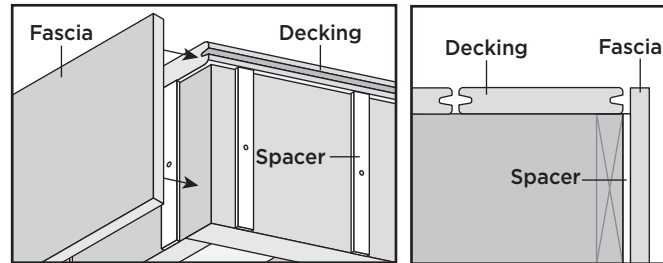

Install 3/16" to 1/4" thick x minimum 1" wide exterior grade spacers (these should be cut the same length as the rim joist), and spaced 9" on center. Install fascia screws as stated below at spacer locations (ensure that spacer screw does not interfere with fascia screw).

# TREX® FASCIA INSTALLATION RECOMMENDATIONS

## WHEN USING DECK BOARDS AND COMPOSITE DECKING FASTENERS FOR FASCIA.

While Trex prefers the previous methods of attachment for fascia applications, as these are the very best options, there are also other recommendations that can be followed for deck boards being used for fascia. Use two Trex recommended composite decking screws every 12". **NOTE THAT FASCIA APPROVED FASTENERS CANNOT BE USED IN THIS APPLICATION. IN ADDITION ALWAYS refer to manufacturer instructions to ensure that recommended screws can be used for fascia applications.** The top screw should be placed 1" from the top of the rim joist, and the second screw 1" from the bottom of the rim joist.

**\*\*IN ADDITION**, also use a weather-resistant, construction-grade adhesive (adhesives that work with wood will work with Trex products) as a **SECONDARY** fastener when attaching deck boards used for fascia. Remember to wipe away any excess before it dries or is allowed to drip onto other Trex surfaces.

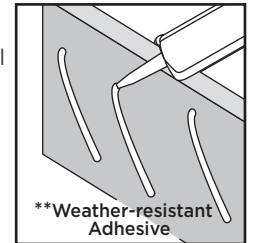

All images shown here reflect fascia under the decking and using approved composite fasteners and decking product for fascia applications.

NOTE: English measurements are shown. Convert to metric measurements if necessary.

NOTE: Adhesive is also required as stated within instructions.

All images shown here reflect fascia under the decking as well as using approved fascia screws.

NOTE: English measurements are shown. Convert to metric measurements if necessary.

### TREX RECOMMENDED FASCIA FASTENERS:

- Cortex® Hidden Fastening System for Fascia
- Starborn® Pro Plug® System for Fascia – Epoxy & Stainless
- Starborn® Deckfast® Fascia System – Epoxy Coated and Headcote® Stainless
- SplitStop™ Fascia Screws
- Simpson Strong-Tie® Fascia Board Screw
- FastenMaster® TrapEase® Fascia Fastener

# ROOFTOP AND SLEEPER DECK SYSTEMS - PRESSURE-TREATED FRAMING

A sleeper system is a substructure between a solid surface and Trex decking. Drainage, access, and airflow are critical. Water must be able to flow through and away from the deck. For repairs and removal of debris, joist system access may be necessary.

NOTE: English measurements are shown.  
Convert to metric measurements if necessary.

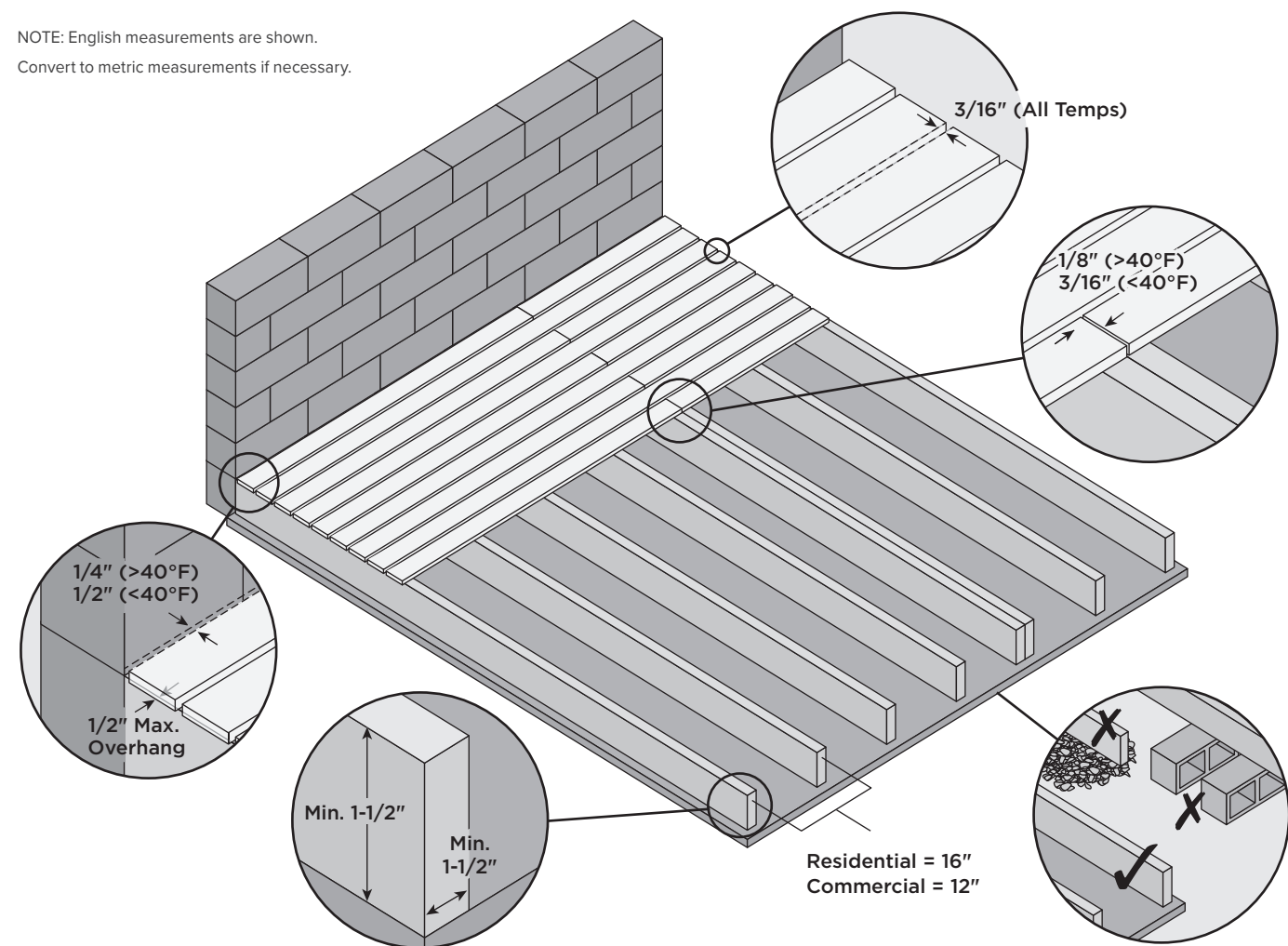

- » It is recommended that building-code approved structural material be used as the supports.
- » This system should not be allowed to float. It must be attached in a manner that secures the framing/system.
- » The sleeper system must be level and have no uneven undulations. Any uneven areas of the substructure will transfer to the Trex decking, resulting in uneven decking.
- » Trex, when used with a sleeper system, must be supported below its entire length. If using in a roofing application, the supports must run the direction of the pitch of the roof to facilitate proper drainage. Sleeper should be placed perpendicular to the deck board orientation.
- » For commercial applications, consult a local building code official for specific requirements.
- » If installing decking at an angle, decrease spans 4" (100 mm) for each of the above. (12" (305 mm) for residential and 8" (204 mm) for commercial.)
- » For sleeper systems where small debris (pine needles, leaves, sand, dirt) can accumulate either between or under deck boards, a minimum of 1-1/2" (38mm) height is allowable. Trex

recommends the use of Trex Universal Hidden Fasteners or 2" Starborn Cap-Tor® xd - Epoxy Coated screws.  
NOTE: Trex recommended composite decking screws are too long when using 1-1/2" (38 mm) height as this will penetrate through the sleeper. For areas with the potential for debris buildup, a minimum 3-1/2" (89 mm) or greater height is recommended to allow the debris to be removed along with the use of either Trex Universal Hidden fasteners or any Trex recommended screws.

- » Always consult your local building code authority for proper details on roof and railing installation to the roof structure if required.
- » Any deviation from these recommendations could result in voiding of the Trex warranty.

# FRAMING AND FASTENING TIPS

## FASTENING TIP FOR TREX SIGNATURE®

NOTE: When using pneumatic or battery-operated equipment, adjust the pressure so that you only shoot the head of the screw to be flush with the board's cap. DO NOT shoot the fastener head completely through the shell.

In most cases, install fasteners at a 90° angle (perpendicular to the board).

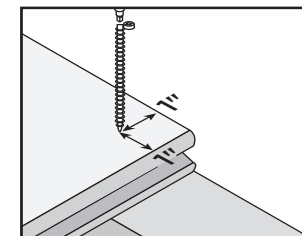

## CLEAN CUT BOARDS

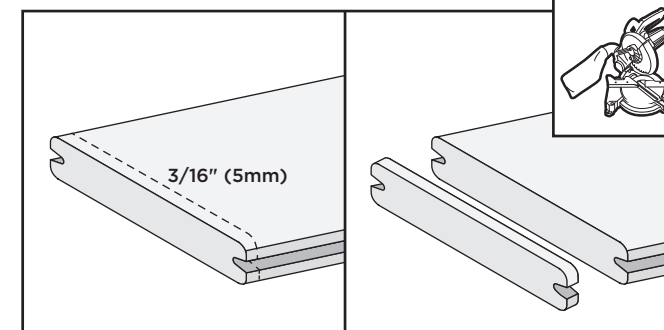

At board ends on the deck's edge, you can install screws placed perpendicularly at the recommended distance, at minimum of 1" (25mm) from the board end and edge, without splitting the board.

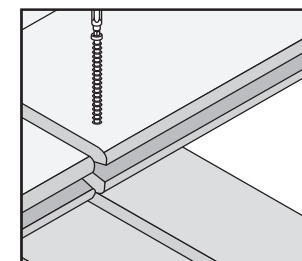

For butt joints, where boards meet over a single joist, add a 2" x 4" "nailer" board at the butt joint. This allows screw-in at 90 degrees and allows fasteners to be used at end of each board.

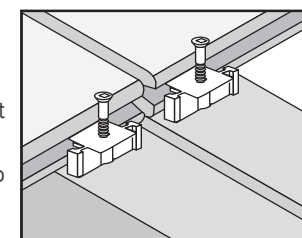

It is recommended that boards be clean cut on both ends a minimum of 3/16" (5mm). Ensure board ends are cut square.

Composite decking is a great alternative to traditional wood decking. When building your deck and railing, it is recommended that code-approved structural material be used as the framing and joists. Check your local building codes for restrictions. Trex decking cannot be used for structural applications. Do not attach Trex decking directly to any solid surface or watertight system.

## DOCK APPLICATIONS

Trex decking contains no materials that will harm marine life and is safe for the environment. As long as dock is in intermittent contact with water, i.e., splashing and not in continuous direct contact with water, the durability of the Trex decking should not be affected.

For docks, a 3/8" (10mm) width-to-width gap between boards is recommended to allow for increased drainage due to increased contact with water. In addition, stainless steel fasteners should be used. If there is sufficient contact between the dock and gasoline, grounding of the dock is also recommended.

## Special Patterns

When planning a unique pattern, you will need to adjust the framing to support the surface pattern. Many decks are designed to take advantage of angles, as shown below.

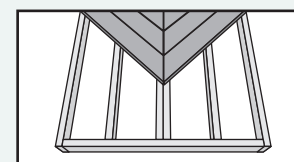

Herringbone Pattern

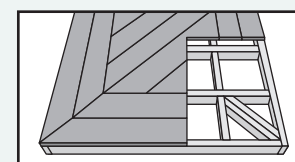

Picture Frame Pattern

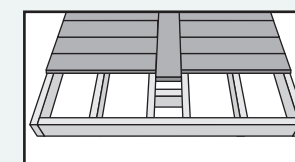

Breaker Board Single Joist

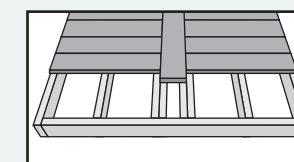

Breaker Board Double Joist

## CODE COMPLIANCE

### Joist Spanning for Decking

Trex decking meets all applicable national model building codes. The joists must be spaced on center according to the chart below. Be sure that joists are level and plumb. Trex decking must span at least three joists. For heavy items such as hot tubs, planters, etc., consult a local building engineer or inspector for span recommendations. If you want to minimize the appearance of joists through the spaces between boards, paint the top of your joists black.

For a Safety Data Sheets (SDS), please visit [www.trex.com](http://www.trex.com).

**ADJUST JOIST SPANNING TO ACCOMMODATE ANGLED DECKING PATTERNS**

90°

Perpendicular to joists. See chart below.

60°

At a 60° angle, maximum joist spanning is 2" (51 mm) less than listed in the chart below.

45°

At a 45° angle, maximum joist spanning is 4" (102 mm) less than listed in the chart below.

30°

At a 30° angle, maximum joist spanning is 1/2 of the distance listed in the chart below.

**TREX DECKING SPAN CHART (ON CENTER)**

	Residential Decks, Light Duty Docks, Residential/Day Care Playground	Commercial Decks, Boardwalks and Marinas	
Decking Loading	100 psf = 4.8 kN/m <sup>2</sup>	100 psf = 4.8 kN/m <sup>2</sup>	200 psf = 9.5 kN/m <sup>2</sup>
1" (25 mm) Boards	16" (406 mm)	16" (406 mm)	12" (305 mm)

## GAPPING AND OVERHANG

You must gap Trex decking both end-to-end and width-to-width. Gapping is necessary for drainage and the slight thermal expansion and contraction of Trex decking boards. Gapping also allows for shrinkage of the wood joist system.

- » ALWAYS follow Trex-recommended gapping guidelines.
- » Maximum allowable perpendicular overhang for all Trex decking is 3/4" (19 mm).
- » All decks require air circulation to keep them dry and looking good. To improve air flow, leave openings under the decking or increase gapping to 3/8" (10 mm).

### WIDTH-TO-WIDTH GAP

3/16" (5 mm)

### END-TO-END/END-TO-WIDTH AND ABUTTING GAP

	End-to-End/ End-to-Width	Abutting Gap
Above 40°F* (4.5°C)*	1/8" (3 mm)	1/4" (6 mm)
Below 40°F* (4.5°C)*	3/16" (5 mm)	1/2" (13 mm)

\*Temperature at installation.

When you use the recommended hidden fasteners, the placement of the hidden fastener establishes the designated gap size. When installing fascia, gapping rules must apply.

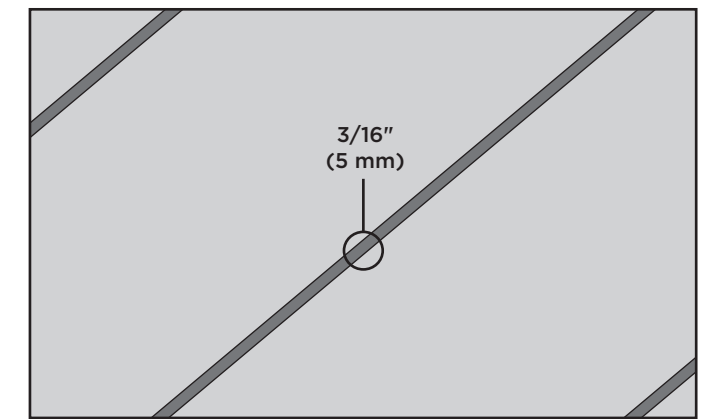

### Width-to-Width

The minimum required width-to-width gapping is 3/16" (5 mm). This is allowed for both hot and cold weather installations. For docks and heavily wooded areas, Trex recommends a 3/8" (10 mm) gap. No gapping should ever exceed 1/2" (13 mm).

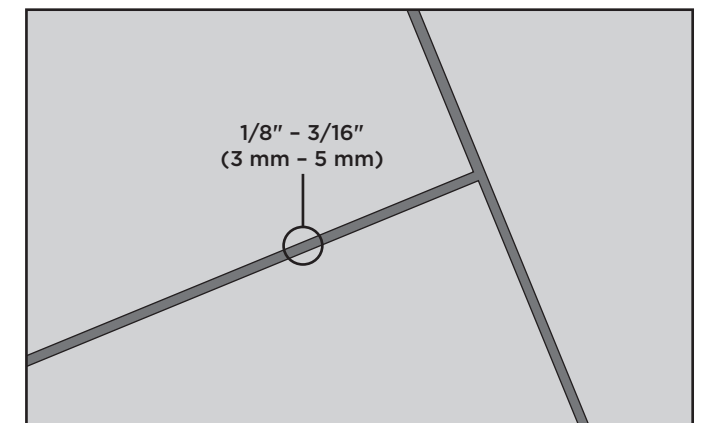

### End-to-End/End-to-Width

Gap Trex decking end-to-end, based upon the temperature at installation. See chart at left. For fastening tips, see page 11.

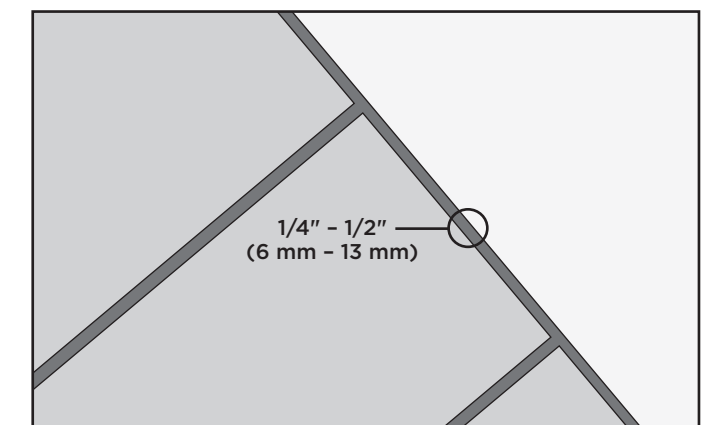

### Abutting Solid Objects

When decking is abutting a wall, you must also gap it 1/4"-1/2" (6-13 mm) depending on the temperature at installation. See chart to the left.

# IMPORTANT NOTES BEFORE INSTALLING TREX® DECKING

It is recommended to clean cut boards on both ends a minimum 3/16" (5mm).

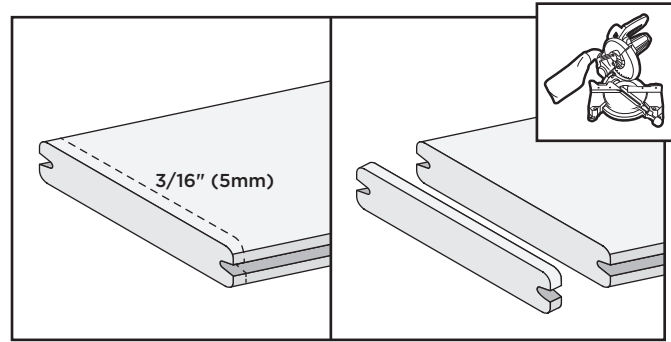

If installing in locations prone to large temperature shifts within a 24-hour period, and installing Trex Universal Hidden Fasteners, predrill and toenail a screw (use same screw used in hidden fasteners) at an angle in groove at both ends (at least 1" (25mm) from board end) and center of each board.

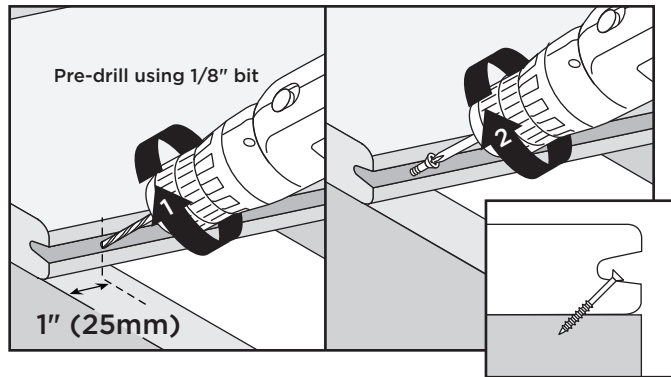

## Routing Square Edge Boards for Trex Hideaway Hidden Fasteners

NOTE: All Trex square edge profiles, either 1 x 6 or 2 x 6, can be routed.

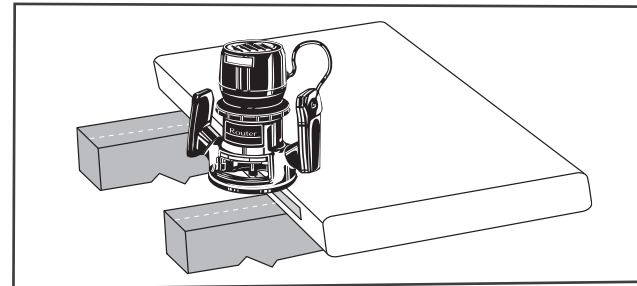

Using a Trex router bit with standard router.

1. Rout from bottom side of board.
2. Rout the entire length of the board, or at every intersection where board is over support joists.

To Ensure an appealing mix of color tones, mix and match all boards prior to installation.

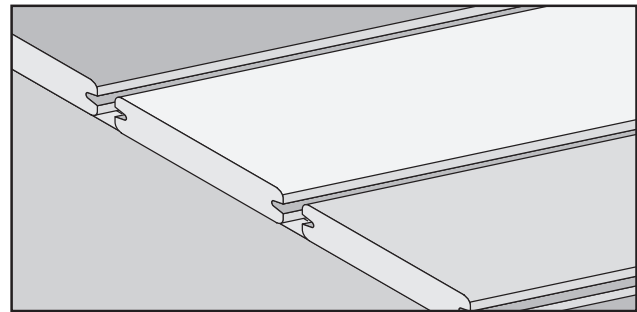

## Abutted Board Attachment Requirements.

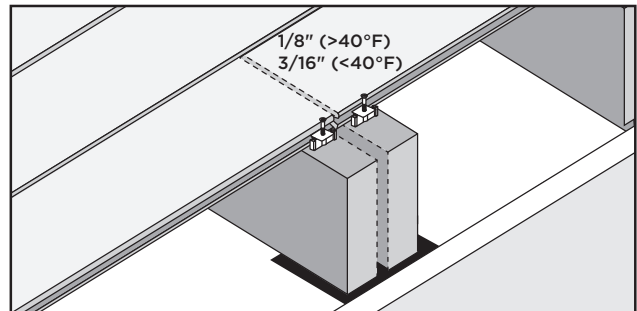

NOTE: Optional- Gap joist framing 1/8" - 1/4" to allow for water drainage.

# TREX HIDEAWAY® ONE-STEP HIDDEN FASTENER TOOL INSTRUCTIONS

The Hideaway® One-Step Installation Tool increases installation speed by allowing you to install the fastener in one easy step. With this tool you can fully actuate the fastener and still install your next deck board, converting what's normally a two-step process into a one-step installation process.

## One-Step Hidden Fastener Tool

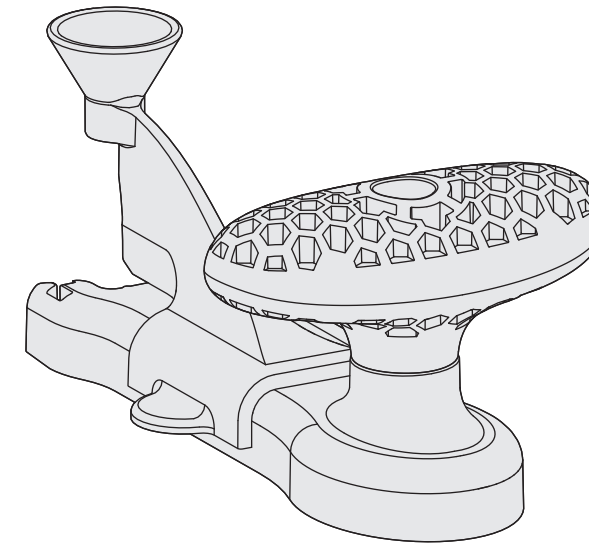

## One-Step Hidden Fastener Tool Bit

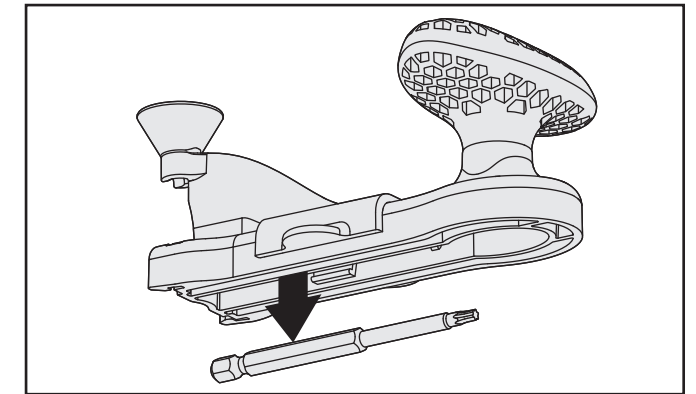

The bit supplied with the Trex Universal Fasteners and the One Step Tool are the same bit, and both are compatible with the tool. Turned down T10 bits from other manufacturers will also work, but please ensure the turned down portion (the narrow nose) is at least 1-1/2" long. Using an inappropriate bit will not allow fasteners to seat correctly and could damage the tool. Bit is conveniently located on the underside of the one-step tool. For replacement Trex® bits please visit [Shop.Trex.com](http://Shop.Trex.com).

## Handle Adjustment

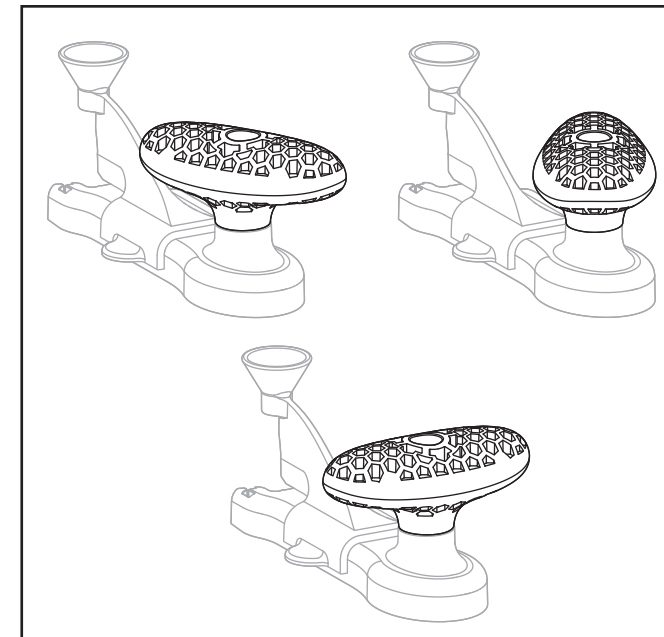

Handle is adjustable and can be loosened and rotated using a 3/16" hex tool to a comfortable position for the user.

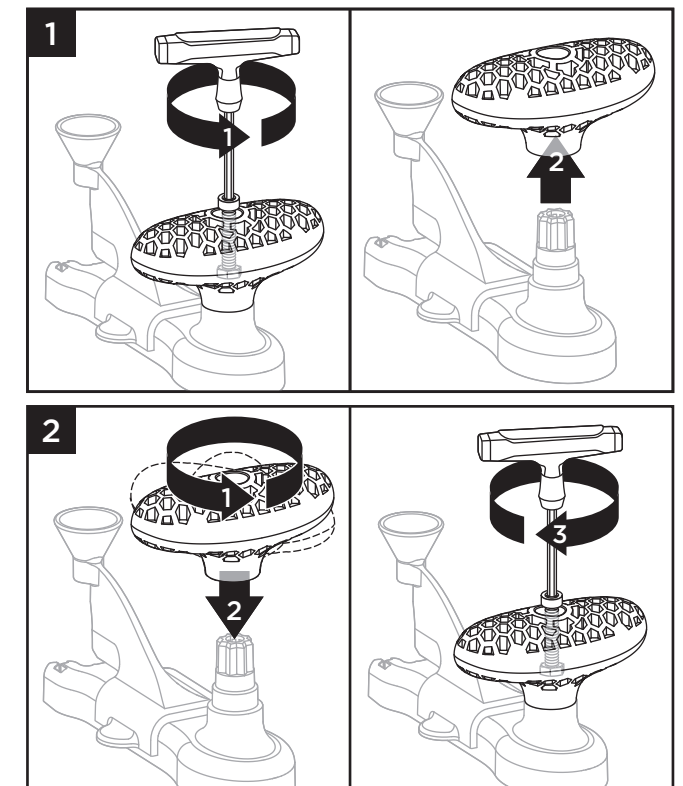



# TREX HIDEAWAY® ONE STEP HIDDEN FASTENER TOOL INSTRUCTIONS / CONTINUED

Note: See instructions included with Trex Hideaway Universal Hidden Fasteners for general rules including clean cutting board ends, gapping rules, abutted board rules and installation of angled deck boards, as well as start clip instructions, steps to take for large temperature shifts and installation of last deck board.

## Installation Instructions

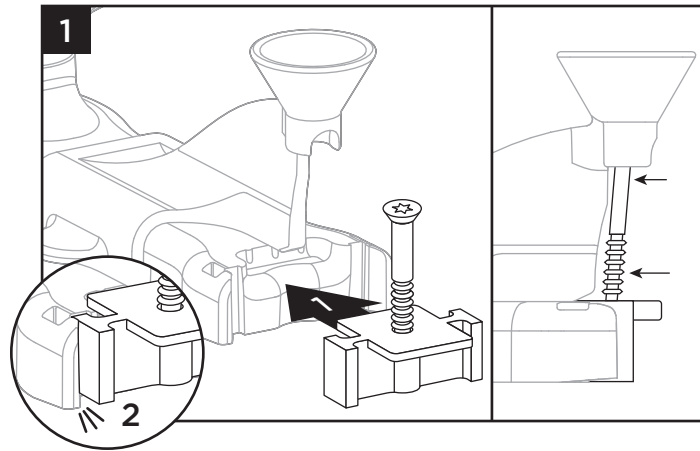

1. Place Hideaway hidden fastener into one-step tool. There will be a slight click when fastener is engaged properly. Screw will also be slightly at an angle when engaged in one-step tool properly.

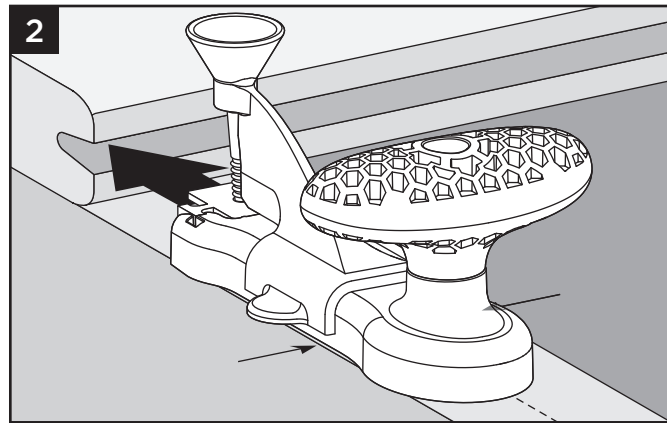

2. Center one-step tool (with fastener included) on joist and push into groove of board.

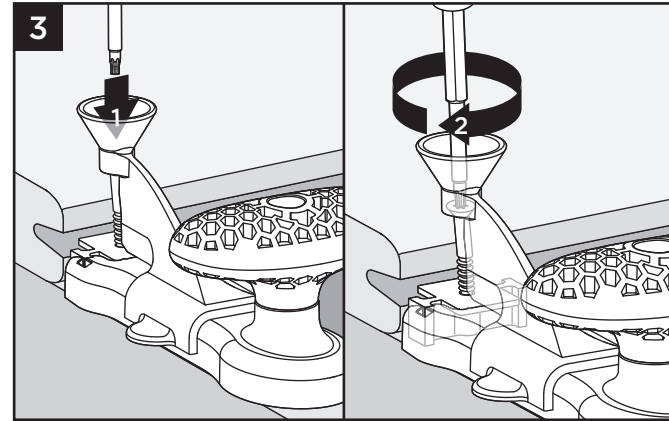

3. Using bit included with one-step tool, install screw as shown. Screw should be slightly countersunk into fastener when installed correctly. Continue to install fasteners on every joist. Do Not Overdrive Screw.

NOTE: Signs of overtightening would be the tool getting stuck and unable to remove properly and/or signs that the shaft of the bit is damaging the conical screw guide.

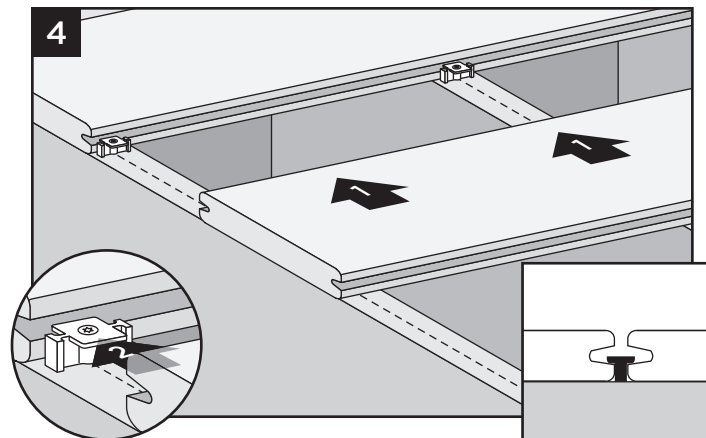

4. Install next board against installed hidden fasteners. Some slight force (using a rubber mallet) to seat next board against fasteners may be required.

# INSTALLING TREX SIGNATURE® DECKING

Note: These instructions should be followed when NOT using the One-Step Tool.

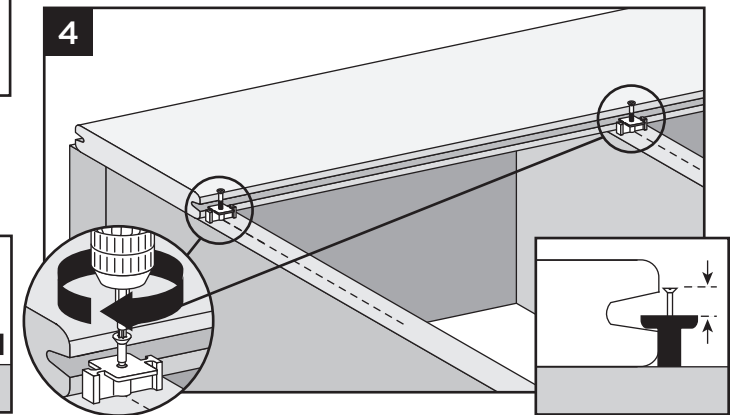
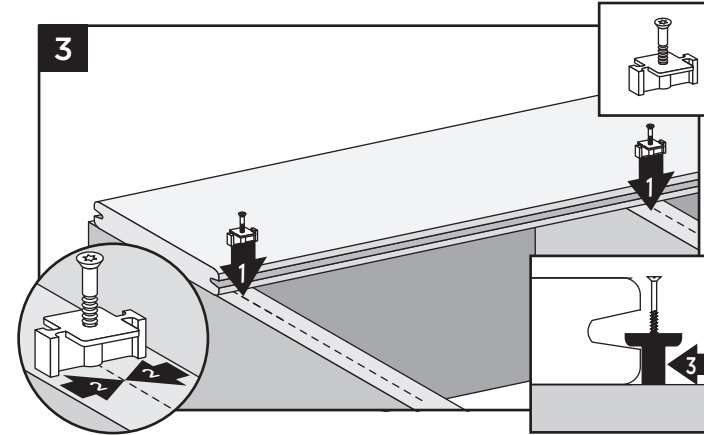
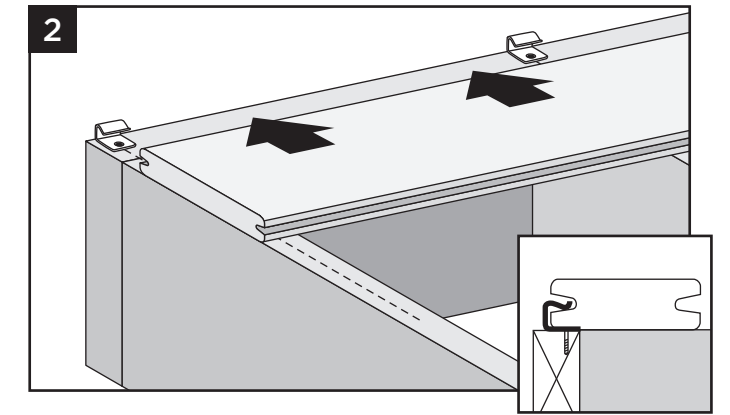
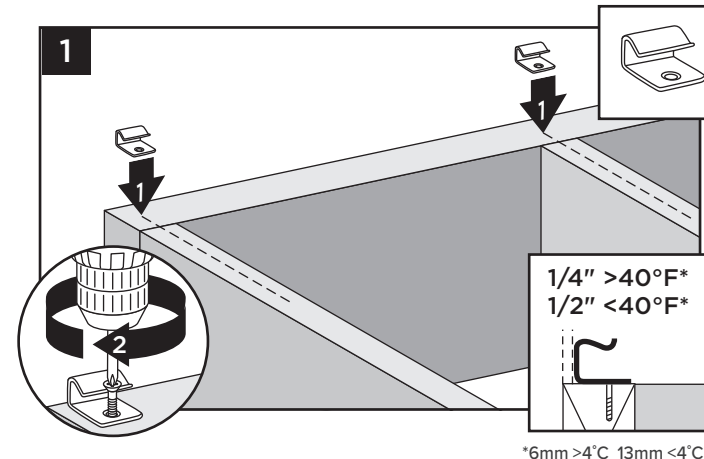

NOTE: Use scrap piece of decking to help hold fastener in place while attaching.

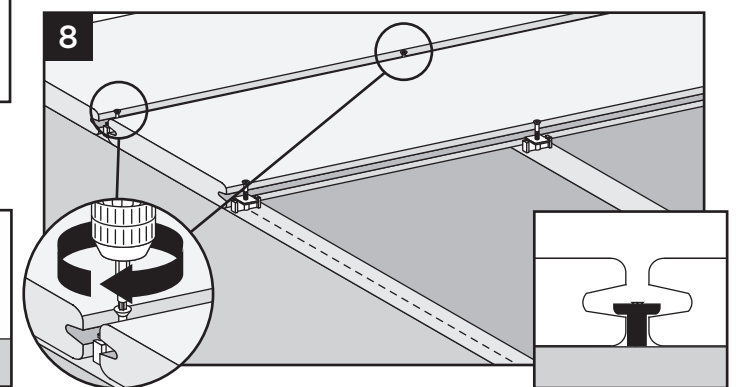
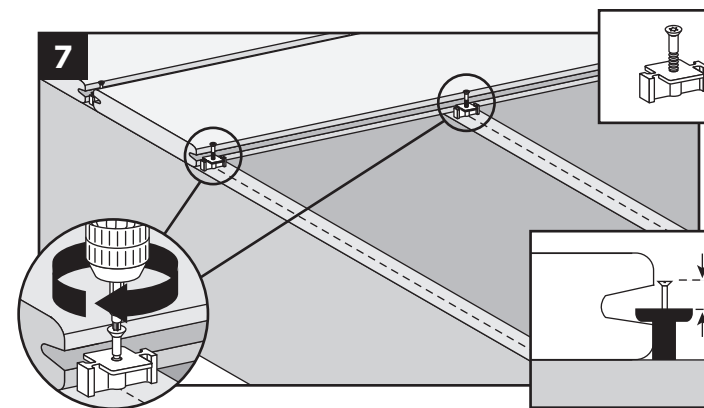
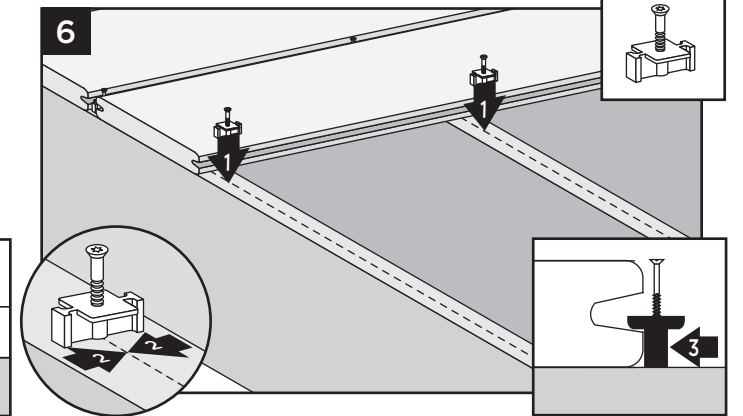
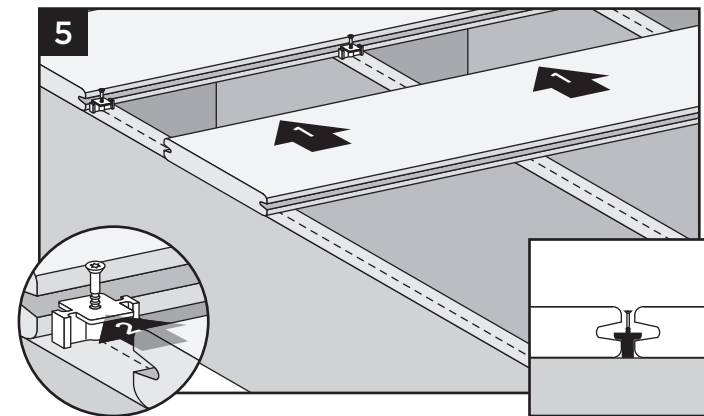

# INSTALLING TREX SIGNATURE® DECKING / CONTINUED

INSTALLING LAST DECK BOARD (SQUARE-EDGE BOARD RECOMMENDED)

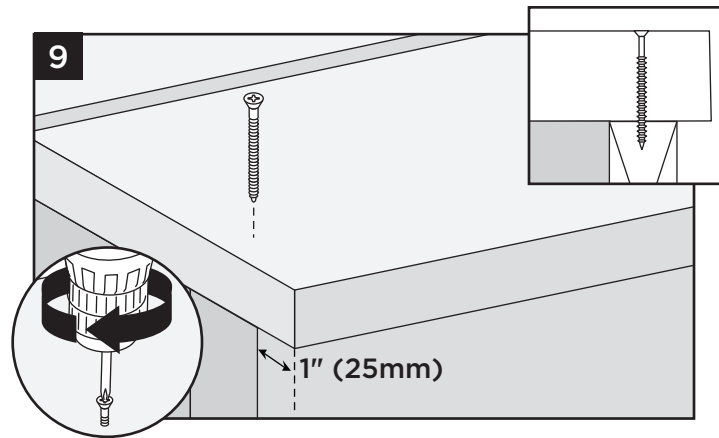

Route one side of square-edge board to use with hidden fasteners.

TIP: Use a recommended hidden fastener screw and plug for last board installation.

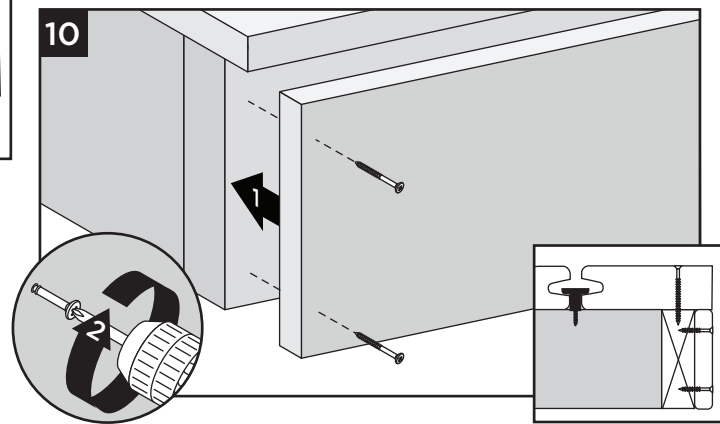

(1" x 8" fascia shown for reference)

# REPLACING TREX SIGNATURE® DECKING

Installed with Trex Hideaway® Universal Fasteners

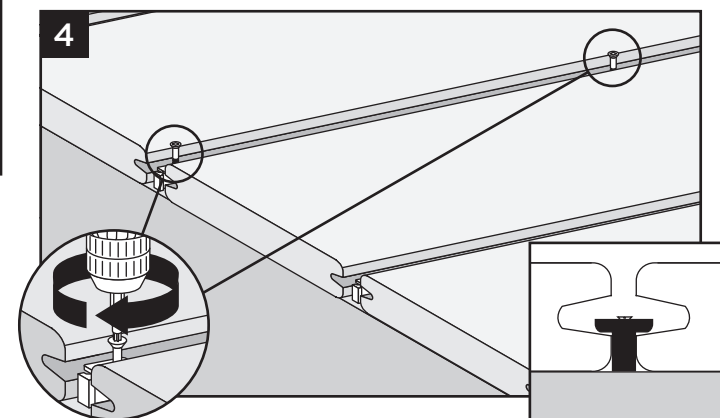
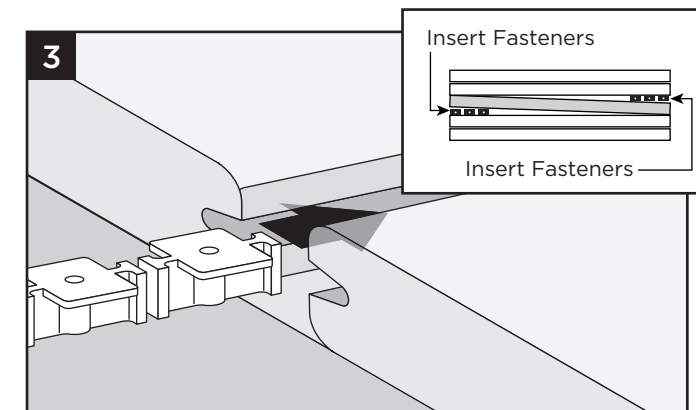
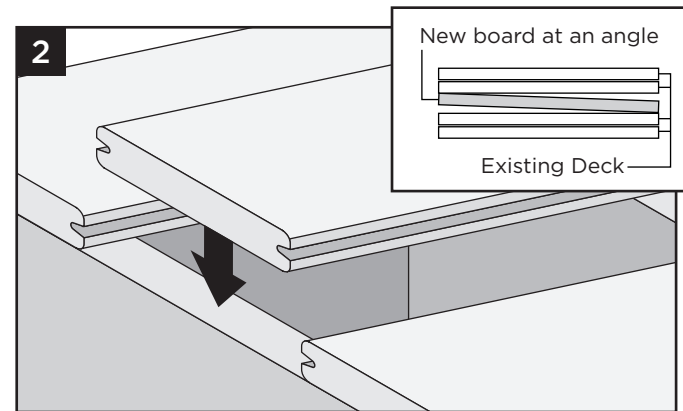
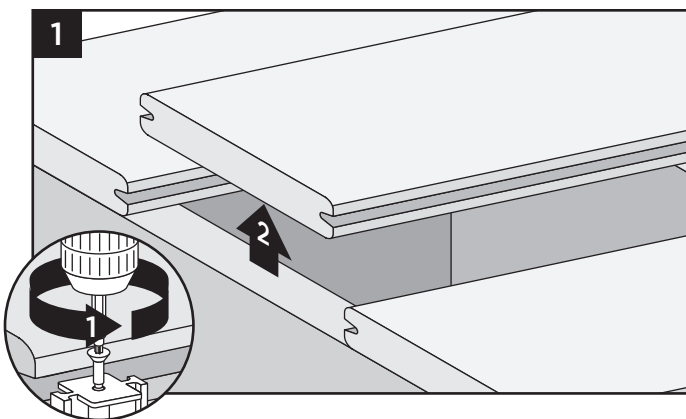

# SPANNING REQUIREMENTS FOR TREX® STAIRS

Note: English measurements are shown. Convert to metric measurements if necessary.

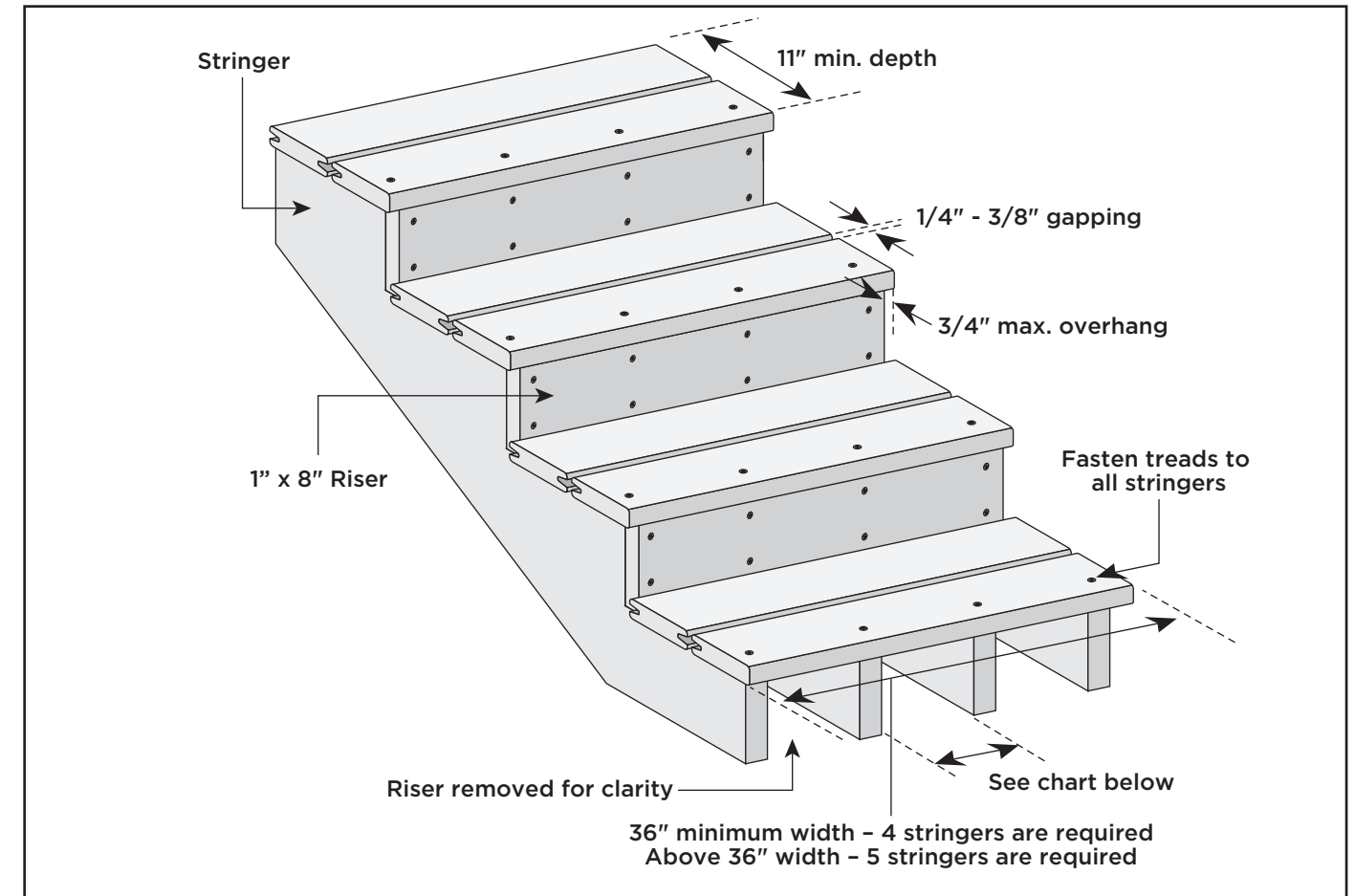

## STAIRS

### Stairway Detail

- » Stair treads built with Trex meet requirements of the major national building codes. Consult your local municipality for specific requirements.
- » Fasten stair treads continuously across at least four stringers.
- » See chart (to the right) for center-to-center spacing of profiles.
- » Dress the sides of the stringers and risers with trim or Trex fascia for a finished look.
- » When installing risers, use two screws per every stringer.
- » Most model building codes require the stair treads to be constructed under the following requirements:
  - › Stairways must be at least 36" wide\*
  - › Stair treads must be at least 11" deep
- » Gapping between Trex boards on stair treads must be 1/4"-3/8".
- » The overhang of the stair tread is not to exceed 3/4".

### NOTES:

- » Trex rails meet all major building codes for use as a guardrail system. Local municipalities may require a graspable handrail on stairways. Check with your local building code official for local requirements. See Trex ADA Handrail System in the Trex product catalog.

### MAXIMUM SPACING ON CENTER OF STAIR STRINGER

Signature 1" x 6"	12"
-------------------	-----

\*For railings that are installed directly over stair treads, the stair treads may need to be larger than 36" wide. Refer to local building code regulations for details prior to installing stairs and railings.

# INSTALLING TREX® STAIR TREADS

## INSTALLED WITH HIDDEN FASTENERS

NOTE: If using hidden fasteners, use square-edge, composite decking boards and manually route these on required sides to allow for use with hidden fasteners. In addition, if not using hidden fasteners, square-edge boards can all be used and face fastened using Trex recommended fasteners.

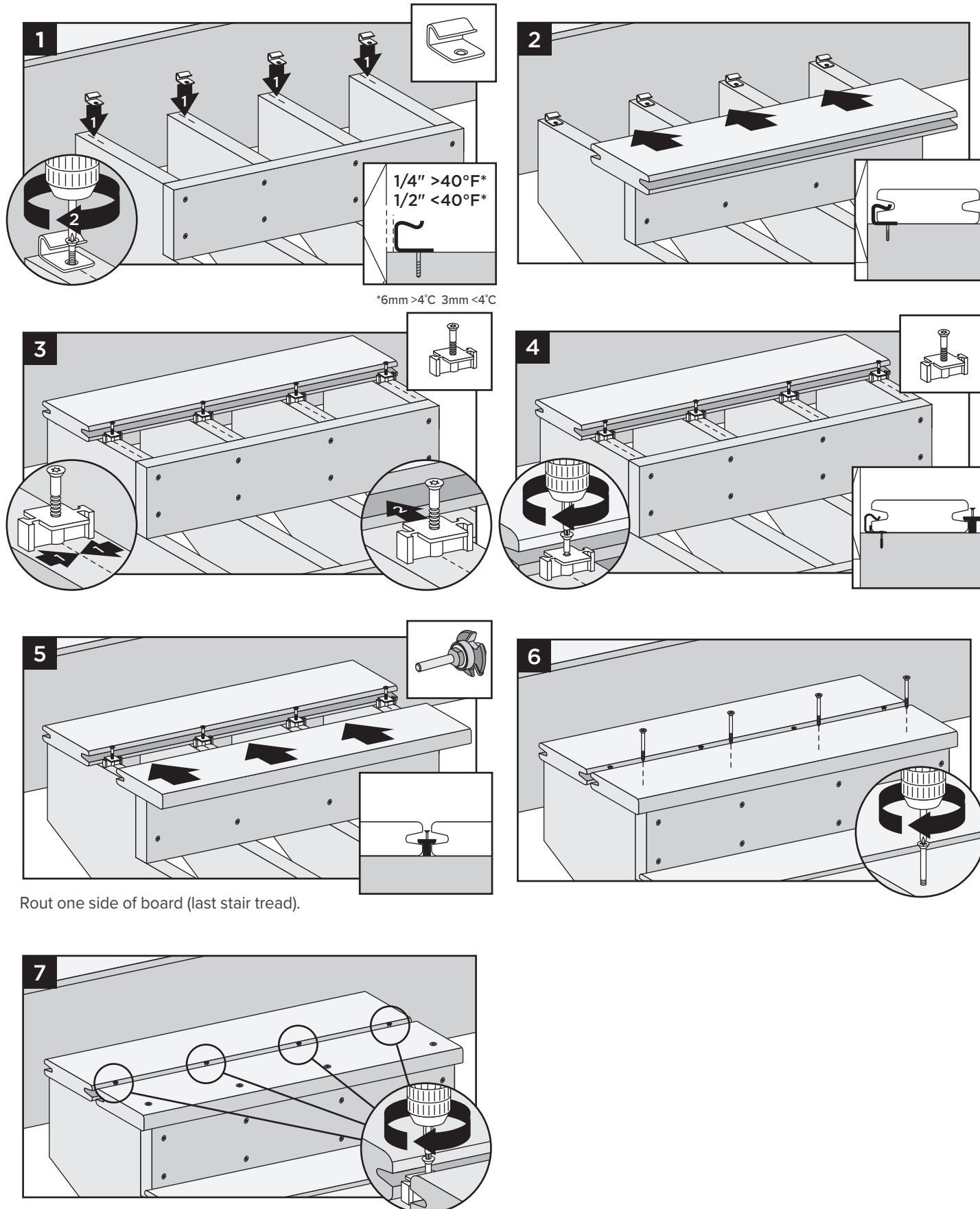

# TREX® DECKING LIMITED WARRANTY

Trex Company, Inc. (hereinafter "Trex") warrants to the original end-use purchaser ("Purchaser") that, for the applicable Warranty Period set forth in Table I below, when properly installed, used and maintained under normal use and service conditions and in accordance with Trex's written instructions, Trex® product set forth in Table I below (the "Product") shall perform as follows:

**Physical Integrity:** The Product shall be free from material defects in workmanship and materials, and shall not split, splinter, rot or suffer structural damage from termites or fungal decay.

**Fade Resistance:** The Product shall not fade in color from light and weathering exposure as measured by color change of (a) more than 5 Delta E (CIE) units for twenty-five years from the date of original purchase, and (b) more than 15 Delta E (CIE) units for the remainder of the Warranty Period, if any.

While the Product is designed to resist fading, no material is fade proof when exposed to years of UV exposure and the elements. The Product is designed to resist fading under normal weather conditions and will not fade by more than the number of Delta E (CIE) units indicated above.

**Stain Resistance:** The Product shall be resistant to permanent staining resulting from spills of food and beverage items including ketchup, mustard, salad oils, tea, wine, coffee, fruit punch, barbecue sauce, sodas and other food and beverage related items that would typically be present on a residential deck, or mold and mildew naturally occurring in the environment, provided that such substances are removed from the Product with soap and water within one (1) week of exposure of the food or beverage to the surface or first appearance of the mold and mildew. Cleaning procedures are described in the Care & Cleaning Guide at [www.trex.com](http://www.trex.com).

Notwithstanding the foregoing, Trex does not warrant that the Product is stain-proof and does not warrant stain resistance resulting from spilled or otherwise applied food and beverage substances which are not properly cleaned as provided above within one (1) week of exposure. In addition, materials not covered in this stain resistance section of this Limited Warranty include abrasive compounds of acidic or basic pH, paints or stains, strong solvents, metallic rust or other abnormal deck use items, and non-food and non-beverage substances, including but not limited to, biocides, fungicides, plant food, bactericides, cement, concrete, mortar, stucco and colored chalk. Mold and mildew can settle and grow on any outdoor surface, including this Product. You should periodically clean your deck to remove dirt and pollen that can feed mold and mildew. This Limited Warranty does not cover mold and mildew which is not properly cleaned as provided above within one (1) week of first appearance.

**Residential/Commercial Application:** For purposes of this Limited Warranty, a "residential application" shall refer to an installation of the Product on an individual residence, and a "commercial application" shall refer to any installation of the Product other than on an individual residence.

**Term of Limited Warranty:** The term of this Limited Warranty for a Product (the "Warranty Period") begins on the date of original purchase and shall be equal to the number of years set forth next to such Product in Table I below.

TABLE I

Product	Residential Warranty Period	Commercial Warranty Period
Signature® decking and fascia	50 Years	10 Years
Transcend® decking and fascia	50 Years	10 Years
Transcend® cladding	50 Years	25 Years
Select® decking and fascia, Universal fascia	35 Years	10 Years
Enhance® decking and fascia	25 Years	10 Years

**Transferability:** With respect to a residential application, this Limited Warranty may be transferred one (1) time, within the five (5) year period beginning from the date of original purchase by the Purchaser, to a subsequent buyer of the property upon which the Product was originally installed. With respect to a commercial application, this Limited Warranty is freely transferable to subsequent buyers of the property upon which the Product was originally installed.

### EXCLUSIONS FROM WARRANTY COVERAGE

The Products must be stored, handled, installed, used and maintained in accordance with instructions provided by Trex, and this Limited Warranty is conditioned upon compliance with all such instructions. Copies of Trex's Installation Guides, Technical Information and Care and Cleaning Guides are available from Trex at the address listed below. The materials may also be obtained on Trex's website at [trex.com](http://trex.com).

Any information or suggestion by Trex with respect to the Products concerning applications, specifications or compliance with codes and standards, including building or safety codes, is provided solely for Purchaser's convenient reference and is made without any representation as to accuracy or suitability. Purchaser must verify and test the suitability of any information with respect to the Products for Purchaser's specific application.

This Limited Warranty does not cover defects caused by:

**Exposure to Heat:** Direct or indirect contact with extreme heat sources (over 275°F/135°C) may cause fading and may damage the surface of the Product, and any effects of such exposure are expressly excluded from coverage under this Limited Warranty.

**Surface Damage:** Never use metal shovels or sharp-edged tools to remove snow and ice on the surface of the Product. If the surface of the Product is damaged or punctured, this Limited Warranty will be voided.

**Paint or Other Materials Applied to the Product:** If paint, solvents or other coating materials are applied to the Product, this Limited Warranty will be voided.

**Other Exclusions:** This Limited Warranty shall not cover any condition attributable to: (1) improper installation of the Product and/or failure to abide by Trex's installation guidelines, including but not limited to improper gapping; (2) use of the Product beyond normal use or service conditions, or in an application not recommended by Trex's guidelines and local building codes; (3) movement, distortion, collapse or settling of the ground or the supporting structure on which the Product is installed; (4) any act of God (such as flooding, hurricane, earthquake, lightning, etc.), environmental condition (such as air pollution, mold, mildew, etc.), staining from foreign substances other than food and beverages (such as dirt, grease, oil, etc.); (5) improper handling, storage, abuse or neglect of the Product by Purchaser, the transferee or third parties; (6) any fading or staining not on the walking surface of the Product (i.e., the underside or the ends of the Product); or (7) ordinary wear and tear.

**Excluded Products:** This Warranty shall not apply to any Trex products not listed in Table I, including, but not limited to, Trex Transcend® railing, Trex Enhance® railing, Trex Select® railing, Trex Signature® railing, Trex Decklighting™ products, TrexTrim™ products, Trex® outdoor lighting products, Trex Hideaway® Fasteners, and Trex® fencing, which are excluded from this Limited Warranty. Each of these products has a separate Limited Warranty.

### PROCEDURE FOR MAKING A CLAIM UNDER THIS LIMITED WARRANTY

To make a claim under this Limited Warranty, Purchaser must do the following:

1. If the Purchaser is making a claim relating to the Limited Warranty on stain resistance, Purchaser must do as follows:

(a) Purchaser must try to clean the affected area of the deck by using the cleaning procedures described above (and provided in more detail in the Care & Cleaning Guide found at [www.trex.com](http://www.trex.com)) within one (1) week of exposure of the food or beverage to the Product or first appearance of the mold and mildew.

(b) If the affected area remains reasonably unsatisfactory after Purchaser has tried these cleaning procedures, then Purchaser must have the affected area of the deck professionally cleaned at Purchaser's expense.

(c) If the affected area remains reasonably unsatisfactory after the professional cleaning, Purchaser may make a claim under this Limited Warranty, provided that such claim is made within thirty (30) days after the professional cleaning.

2. To make a claim under this Limited Warranty, Purchaser, or the transferee, shall send to Trex, within the Warranty Period referred to above, a written description and photographs of the claimed defect, proof of purchase, and if the claim relates to the Limited Warranty on stain resistance, proof of compliance with paragraph 1 above, to the following address:

Trex Company, Inc.  
Customer Relations  
160 Exeter Drive  
Winchester, VA 22603-8605



TREX® DECKING LIMITED WARRANTY (continued)

3. Upon confirmation by an authorized Trex representative of a valid claim hereunder, Trex's sole responsibility shall be, at its option, to either: (a) replace the affected Product with new Product in an amount equal to the volume (linear feet) of defective material; or (b) refund the portion of the purchase price paid by Purchaser for such affected Product (not including the cost of its initial installation). Replacement Products will be as close in color, design, and quality to the original Products as reasonably possible, in Trex's discretion and determination, but Trex does not guarantee an exact match as colors and designs may change and Trex's obligation as to replacement shall further be limited to replacement with the styles and colors of the Product that are available at the time of the replacement. **THE REMEDIES STATED IN THIS PARAGRAPH ARE PURCHASER'S SOLE AND EXCLUSIVE REMEDIES FOR ANY PRODUCT THAT FAILS TO CONFORM TO THIS LIMITED WARRANTY.**

If a valid warranty claim hereunder is made during year eleven (11) or any year thereafter through the expiration of the applicable Warranty Period after the original purchase, recovery will be prorated in accordance with Table II, below. If Trex is providing replacement materials, it may elect to replace the percentage listed in Table II, below, of boards otherwise meeting the requirements for a claim, or if it is refunding the purchase price, it may elect to refund the percentage listed below in Table II of the purchase price of Product otherwise meeting the requirements for a claim.

TABLE II

Year of Claim	Warranty Period		
	50 Year	35 Year	25 Year
11	90%	80%	80%
12	90%	80%	80%
13	90%	80%	80%
14	90%	80%	60%
15	90%	60%	60%
16	90%	60%	60%
17	70%	60%	40%
18	70%	60%	40%
19	70%	40%	40%
20	70%	40%	20%
21	70%	40%	20%
22	70%	40%	20%
23	50%	20%	10%
24	50%	20%	10%
25	50%	20%	10%
26	50%	20%	—
27	50%	20%	—
28	50%	20%	—
29	30%	10%	—
30	30%	10%	—
31	30%	10%	—

Year of Claim	Warranty Period		
	50 Year	35 Year	25 Year
32	30%	10%	—
33	30%	10%	—
34	30%	10%	—
35	30%	10%	—
36	20%	—	—
37	20%	—	—
38	20%	—	—
39	20%	—	—
40	20%	—	—
41	20%	—	—
42	20%	—	—
43	10%	—	—
44	10%	—	—
45	10%	—	—
46	10%	—	—
47	10%	—	—
48	10%	—	—
49	10%	—	—
50	10%	—	—

**THE LIMITED WARRANTIES SET FORTH HEREIN ARE THE ONLY WARRANTIES MADE BY TREX IN CONNECTION WITH THESE PRODUCTS. TREX DOES NOT MAKE ANY OTHER WARRANTIES, IMPLIED OR EXPRESS, AND DISCLAIMS ALL OTHER WARRANTIES, INCLUDING, BUT NOT LIMITED TO, ANY IMPLIED WARRANTY OF MERCHANTABILITY OR FITNESS FOR A PARTICULAR PURPOSE. TREX'S SOLE OBLIGATION UNDER THIS LIMITED WARRANTY SHALL BE, AT ITS OPTION, REPLACEMENT OF NON-CONFORMING PRODUCTS OR A REFUND OF THE PURCHASE PRICE, AS DESCRIBED ABOVE. PURCHASER ASSUMES ALL RISK WHATSOEVER AS TO THE RESULT OF THE USE OF THE PRODUCTS PURCHASED, WHETHER USED SINGULARLY OR IN COMBINATION WITH ANY OTHER PRODUCTS OR SUBSTANCES.**

**THIS LIMITED WARRANTY SHALL NOT COVER AND TREX SHALL NOT BE RESPONSIBLE FOR COSTS AND EXPENSES INCURRED WITH RESPECT TO THE REMOVAL OF DEFECTIVE PRODUCT OR THE INSTALLATION OF REPLACEMENT MATERIALS, INCLUDING BUT NOT LIMITED TO LABOR AND FREIGHT.**

No person or entity is authorized by Trex to make and Trex shall not be bound by any statement or representation as to the quality or performance of Product other than as contained in this Limited Warranty. This Limited Warranty may not be altered or amended except in a written instrument signed by Trex and Purchaser.

**TO THE FULLEST EXTENT PERMITTED UNDER THE LAW, UNDER NO CIRCUMSTANCES WILL TREX BE LIABLE FOR ANY SPECIAL, INDIRECT, INCIDENTAL, CONSEQUENTIAL, RELIANCE, STATUTORY, SPECIAL, PUNITIVE OR EXEMPLARY DAMAGES, INCLUDING, BUT NOT LIMITED TO, LOST PROFITS, LOSS OF USE, LOSS OF TIME, LOSS OF REVENUES, INCONVENIENCE, LOSS OF BUSINESS OPPORTUNITIES, OR DAMAGE TO GOOD WILL OR REPUTATION DAMAGES, WHETHER SUCH DAMAGES ARE SOUGHT IN CONTRACT, IN TORT (INCLUDING BUT NOT LIMITED TO NEGLIGENCE AND STRICT LIABILITY) OR OTHERWISE, EVEN IF ADVISED OF THE POSSIBILITY OF SUCH DAMAGES OR SUCH DAMAGES COULD HAVE BEEN REASONABLY FORESEEN, IN CONNECTION WITH, ARISING OUT OF, OR AS A RESULT OF, THE SALE, DELIVERY, INSTALLATION, USE OR LOSS OF USE OF THE PRODUCTS SOLD HEREUNDER, OR FOR ANY LIABILITY OF PURCHASER TO ANY THIRD PARTY WITH RESPECT THERETO AND TREX'S LIABILITY FOR NON-PERSONAL INJURY CLAIMS WITH RESPECT TO DEFECTIVE PRODUCT SHALL IN NO EVENT EXCEED THE REPLACEMENT OF SUCH PRODUCT OR REFUND OF THE PURCHASE PRICE, AS DESCRIBED ABOVE.**

Some States or Provinces do not allow the exclusion or limitation of incidental or consequential damages, so the above limitation or exclusion may not apply to you. This Limited Warranty gives you specific legal rights, and you may also have other rights that vary from State to State or Province to Province.

Copyright © 2023 Trex Company, Inc.

DECKING COLOR PALETTE



whidbey

Retreat to an island of misty cliffs, where salt-washed fog rolls in like a morning blanket.



ocracoke

Escape to a secluded island sheltered by sandy dunes and marshy shores.

# TREX SIGNATURE®

Contact our Signature Concierge to start your journey.

Email [concierge@trex.com](mailto:concierge@trex.com) or call **855.411.1045**

[SIGNATURE.TREX.COM](https://signature.trex.com)



Engineering What's Next  
in Outdoor Living®

© 2023 Trex Company, Inc. All rights reserved. Trex®, the Trex logo, Trex Signature®, the Signature logo, Trex® Fascia and Trex Hideaway® are either federally registered trademarks, trademarks or trade dress of Trex Company, Inc., Winchester, Virginia.